



green
energy
lab.at

CLUE *Proof of Concept*



This project has received funding in the framework of the joint programming initiative ERA-Net Smart Energy Systems, with support from the European Union's Horizon 2020 research and innovation programme. The project is associated with the [Green Energy Lab](#) research initiative, part of the innovation offensive "Vorzeigeregion Energie" of the Austrian Climate and Energy Fund.



AUSTRIAN PROOF-OF-CONCEPT DESCRIPTION

FINAL VERSION

Rao Bharath Varsh (AIT), Reihls David (AIT), Reisenbauer Sarah (AIT),
Jung Oliver (AIT), Francesca Soro (AIT),
Clemens Korner (AIT), Denis Vettoretti (AIT),
Carolin Monsberger (AIT), Bernadette Fina (AIT)
Peter Stern (Siemens AG), Stephan Willenig (Siemens AG),
Franz Zeilinger (Siemens AG), Manuel Matzinger (Siemens AG),
Benjamin Thomann (TU Wien), Daniel Hauer (TU Wien)

31 March 2023

INTERNAL REFERENCE

Deliverable No.:	D 4.1 (2023)
Deliverable Name:	Austrian proof-of-concept description
Lead Participant:	AIT
Work Package No.:	WP4
Task No. & Name:	T4.1 – T4.7
Document (File):	D4.1
Issue (Save) Date:	2023-03-31

DOCUMENT STATUS

	Date	Person(s)	Organisation
Author(s)	2022-10-02	Bharath Varsh Rao	AIT
	2022-10-12	Reihs David	AIT
	2023-02-15	Franz Zeilinger	
	2023-02-17	Benjamin Thomann	TUW
	2023-02-19	Daniel Hauer	TUW
	2023-02-25	Frederike Ettwein	FHTW
	2023-03-25	Peter Stern	SIE
	2023-03-25	Reisenbauer Sarah	AIT
	2023-03-29	Stephan Willenig	SIE
	2023-03-29	Clemens Korner	AIT
	2023-03-29	Carolin Monsberger	AIT
	2023-03-29	Bernadette Fina	AIT
	2023-03-29	Thomas Zeinzinger	Lab10
	2023-03-29	Denis Vettoretti	AIT
	2023-03-30	Francesca Soro	AIT
Verification by	2023-03-31	Bharath Varsh Rao	AIT
Verification by	2023-03-31	Franz Zeilinger	
Approval by	2023-03-31	Bharath Varsh Rao	AIT

DOCUMENT SENSITIVITY

- Not Sensitive** Contains only factual or background information; contains no new or additional analysis, recommendations or policy-relevant
- Moderately Sensitive** Contains some analysis or interpretation of results; contains no recommendations or policy-relevant statements
- Sensitive** Contains analysis or interpretation of results with policy-relevance and/or recommendations or policy-relevant statements
- Highly Sensitive Confidential** Contains significant analysis or interpretation of results with major policy-relevance or implications, contains extensive recommendations or policy-relevant statements, and/or contain policy-prescriptive statements. This sensitivity requires SB decision.

TABLE OF CONTENT

- 1 INTRODUCTION 11**
- 2 ELABORATION OF SELECTED BUSINESS MODELS 11**
 - 2.1 Electricity suppliers: 12
 - 2.2 Energy service providers: 13
 - 2.3 Distribution grid operators: 13
 - 2.4 Local authorities: 13
 - 2.5 Financing institutions: 14
- 3 END CUSTOMER ACCEPTANCE AND PARTICIPATION 14**
 - 3.1 General perception of ECs in Austria and CLUE-Demo Regions 15
 - 3.2 Perception of CLUE-AT Use Cases 18
- 4 LEC TOOL KIT - ENERGY COMMUNITY PLANNING 19**
 - 4.1 Scope and Introduction of an Energy Community Planning Tool Approach 19**
 - 4.1.1 Potential Use Cases for a LEC Tool Kit 20
 - 4.1.2 User Story for an Energy Community Planning Tool 27
 - 4.2 Architecture and Components 31**
 - 4.3 Simulation Backend 32**
 - 4.3.1 Community Setup 33
 - 4.3.2 Asset Modelling 35
 - 4.3.3 Flexible asset control 36
 - 4.3.4 Community Market simulation 37
 - 4.3.5 Simulation Execution 38
 - 4.4 BIFROST – Adoptions for LEC Tool Kit Application 39**
 - 4.5 BIFROST – mosaic Coupling 43**
 - 4.6 External Config Tool 43**
 - 4.7 Results 46**
 - 4.7.1 Example for a Planning Workflow 46
 - 4.7.2 Workshop with Project Partners 52
- 5 PROOF-OF-CONCEPT COMMUNITIES/CELLS STYRIA 55**
 - 5.1 Communication and Network 55**

5.1.1	Network and Gateway Concept in Demo Region Gasen	55
5.1.2	Network Topology and System Parts	56
5.1.3	Network topology and System Party in Gasen	58
5.1.4	Used Protocols with Smart Home System.....	59
5.1.5	Siemens SICAM A8000 Gateway	60
5.1.6	SIAPP to Homee – 1 st Connection Test.....	61
5.1.7	SIAPP to Homee – 2 nd Connection Test.....	63
5.1.8	SIAPP to Homee – 3 rd Connection Test	65
5.1.9	Homee Measurement Values Test	67
5.1.10	Homee AIT json-value Test	68
5.1.11	Homee – AEOTEC Data Test.....	69
5.1.12	Test Homee 000551134512 “Biomasse” power / week	69
5.1.13	Test Homee 000551134512 “Biomasse” power / day	70
5.1.14	Test Homee 000551134512 “Biomasse” current / day	70
5.1.15	Test Homee 0005511141FA “Gemeindeamt” power / week	71
5.1.16	Test Homee 000551134530 “Schweiger” power / week	71
5.1.17	Test Homee 0005510E7372 “Grabenbauer” energy / month	72
5.1.18	Test Homee 0005510E7372 “Grabenbauer” energy / week.....	72
5.1.19	Test Homee 0005510E7372 “Seitinger” energy.....	73
5.1.20	Final result.....	74
5.1.21	SIEMENS to AIT REST Interface	74
5.1.22	Firebase API (base for user interface)	75
5.1.23	 Firebase integration test	75
<i>5.1.24</i>	<i> Invalid login credential:.....</i>	<i>75</i>
<i>5.1.25</i>	<i> Network traffic:.....</i>	<i>76</i>
<i>5.1.26</i>	<i> Firebase config upload / download:.....</i>	<i>76</i>
5.1.27	CLUE User Interface	81
5.1.28	Dashboards.....	82
5.1.29	Settings.....	83

5.1.30	Google Firebase.....	84
5.1.31	AIT Rapid Deployment Platform	85
5.1.32	1. New AIT connectivity:	90
5.1.33	Machine learnt distribution system state estimation	91
5.2	Cybersecurity and Intrusion Detection	93
5.2.1	The STRIDE Threat Model	93
5.2.2	Risk Analysis.....	94
5.2.3	Dataset exploration and characterization	104
5.2.4	Detection of anomalies in measurements	105
6	PROOF-OF-CONCEPT COMMUNITIES/CELLS INNOVATION LAB	109
6.1	Establsishing the REC	109
6.1.1	Frame Conditions	109
6.1.2	1st Citizen information workshop	109
6.1.3	Establsishing the REC	109
6.1.4	2nd Citizen information workshop	109
6.1.5	Test phase	109
6.2	The Energy Account	110
6.2.1	General	110
6.2.2	ICT Concept.....	111
6.3	Blockchain Implementation	112
6.3.1	Minerva Wallet.....	113
6.3.2	e-kWh Token	114
6.3.3	API to mint “e-kWh”	114
7	LITERATURE.....	116

Figure 1: self-reported knowledge level of people familiar with EC (in %, n=539)	15
Figure 2: preference for operators of ECs in Austria (in %, multiple choice, n=1073).....	16
Figure 3: Importance-Performance Analysis on EC Characteristics (n=1073).....	17
Figure 4: Using BIFROST to explain the concept of an energy community.....	21
Figure 5: Sketch of the modelled settlement.....	22
Figure 6: Adding data to the modelled settlement	22
Figure 7: Define different variants.....	23
Figure 8: Idea for representation of the results and comparison of different variants or scenarios.....	23
Figure 9: Example of what data and Settings are visible for members and operators of an EC.....	25
Figure 10: Dashboard with non-sensitive information to show externally.....	26
Figure 11: Proposal of the LEC Tool Kit to improve the community operation	27
Figure 12: After defining the EC, scenarios to be investigated are defined	28
Figure 13: Different scenarios can be added in a separate UI	28
Figure 14: For each scenario different options can be investigated.....	29
Figure 15: After the definition phase, for all scenarios the needed calculations are made	29
Figure 16: The results are presented in form of a short summary, based on performance on different KPIs, which represent different goals of the community operation.	29
Figure 17: Now the data can be further investigated in the BIFROST UI.....	30
Figure 18: Here the performance of different assets can be visualized e.g., the storage system.....	30
Figure 19: Also changes can be made an the calculations be redone.....	30
Figure 20: In this example it is shown that a higher capacity of the storage system has only a minor effect on the community performance, so the investment in this bigger storage system will not pay off.....	31
Figure 21: Overview of workflow using CLUE toolset for local energy communities.....	31
Figure 22: Detailed architecture of the Energy Community Planning Tool.....	32
Figure 23: Coupling of the different simulations with the co-simulation approach.	33
Figure 24: Exemplary energy community with community member energy subsets and information exchange via community market.	33
Figure 25: Flowchart of a simulation step of the developed simulation model	34
Figure 26: Technology perspective: Prefetch of simulation data.....	39
Figure 27: Technology perspective: Replay of data based on already made simulations	40
Figure 28: Realisation of the technology perspective of prefetching and replaying of simulation data	40
Figure 29: Technology perspective: Geospatial relations of whole settlement areas	41
Figure 30: from top left to bottom right: Definition of a new settlement based on entering data via a map.....	41
Figure 31: Technology perspective: Geospatial relations within settlement areas	42
Figure 32: Allocation of elements of the schematic view to elements in the map.....	42
Figure 33: Overview of new domain layers in BIFROST	43
Figure 34: Screenshots of the External Config Tool	45
Figure 35: Entering the demo settlement of Gasen, Styria	46
Figure 36: The community should be expanded by a central PV system.....	46
Figure 37:.. which is placed into a near free area,	47

Figure 38: and a community storage system.	47
Figure 39: The new components are connected to the existing electrical grid.	47
Figure 40: After this the External Config Tool is used to configure the interesting scenarios.	48
Figure 41: For each of the scenarios a new set of options can be defined (or copied and then altered).....	48
Figure 42: In the tool all components can be configured, like here.....	48
Figure 43: ... the capacity of the storage system.	49
Figure 44: After defining a simulation period.....	49
Figure 45: the EC Simulation Backend and BIFROST perform all needed calculations and collect the data.....	49
Figure 46: After all simulations are finished the External Config Tool shows a summary in form of a table. Depending on the different KPIs, the best solution for the community in Gasen can be selected.....	50
Figure 47: To investigate certain simulation results, these can easily be activated in the BIFROST UI.....	50
Figure 48... and there visualized, like here at the storage system.....	50
Figure 49: ... the development of the state of charge over the simulation period.....	51
Figure 50: Also a comparison is possible in the BIFROST UI, here the KPI Community Self Sufficiency is compared.....	51
Figure 51... between two scenarios, which are distinguished by the capacity of the storage system.....	51
Figure 52: How do you like the different aspects of the configuration workflow?.....	52
Figure 53: Where do you see the applications areas of the presented toolset (BIFROST + ExtConfig Tool)?.....	52
Figure 54: Which additional domains would improve the presented planing tool for you?	53
Figure 55: Where do you see additional application areas of BIFROST (regardless of the presented toolchain)?	53
Figure 56: Architecture of the AIT Rapid Deployment Platform which is deployed in the demo region Gasen	85
Figure 57: Portainer is used for managing the Docker containers of the AIT Rapid Deployment Platform	86
Figure 58: Dashboard of the database.....	86
Figure 59: Dashboard of the machine which runs the AIT Rapid Deployment Platform..	87
Figure 60: The rapid deployment platform sends an alert to inform about a problem in the received data.....	88
Figure 61: Logs gathered in the AIT rapid deployment platform with Loki	88
Figure 62: Measurements at the xelectrix battery during a test.....	89
Figure 63: Measurements of a customer of the energy community.....	89
Figure 64: REST endpoints of the AIT RDP	90
Figure 65: Left - the grid topology of the investigated test grid 06. Right - The two employed metrics for different fractions of observed locations in the grid in terms of voltages at busbars together with the corresponding loads ($f_{V,PQ}$), averaged over all predicted quantities (avg). Each dot per fraction indicates the average over a different scenario of measurement positions. Dark grey relates to the performance of the ANN model while light grey (slightly shifted to the right for better visibility) originates from the LR.....	92

Figure 66: Example scenarios of measurement device placement and predictability for the test grid 06. Colour indicates if a position was observed (green, dark grey), or not (light grey), or how good the prediction R^2 score was (with a lower bound cut-off value of 0.9 in this case labelled as 'bad metric'). 92

Figure 67: Upper – Prediction metrics for the Gasen grid scenarios with the actual Gasen case located at a fraction of 0.13. The measurement device positioning was not ideal as can be seen from the elevated position in the RMSE trace envelope. Lower – exemplary forecasts for unseen input data from the Gasen demonstrator case trained ML models for two busbars (node_2, node_3). 93

Figure 68: Home screen of the energy account web application 110

Figure 69: main dashboard of the energy account web application 111

Figure 70: overview of the communication architecture for the energy account application 112

Figure 71: Analysis of programmable blockchains and their suitability for CLUE 112

Figure 72: Schematic architecture for the Token Generator to mint e-kWh Tokens 115

Disclaimer

The content and views expressed in this material are those of the authors and do not necessarily reflect the views or opinion of the ERA-Net SES initiative. Any reference given does not necessarily imply the endorsement by ERA-Net SES.

About ERA-Net Smart Energy Systems

ERA-Net Smart Energy Systems (ERA-Net SES) is a transnational joint programming platform of 30 national and regional funding partners for initiating co-creation and promoting energy system innovation. The network of owners and managers of national and regional public funding programs along the innovation chain provides a sustainable and service oriented joint programming platform to finance projects in thematic areas like Smart Power Grids, Regional and Local Energy Systems, Heating and Cooling Networks, Digital Energy and Smart Services, etc.

Co-creating with partners that help to understand the needs of relevant stakeholders, we team up with intermediaries to provide an innovation eco-system supporting consortia for research, innovation, technical development, piloting and demonstration activities. These co-operations pave the way towards implementation in real-life environments and market introduction.

Beyond that, ERA-Net SES provides a Knowledge Community, involving key demo projects and experts from all over Europe, to facilitate learning between projects and programs from the local level up to the European level.

www.eranet-smartenergysystems.eu

1 INTRODUCTION

Local Energy Communities (LECs) are seen as an essential element of the future energy system. These community-led organizations are going to cooperate in the production, distribution, storage, and supply of energy at the local level, with the aim of maximizing on-site generation and the self-consumption of renewable energy.

Local stakeholders, and their energy planners (the need owners), had to be enabled to identify the optimal structure of their LECs in order to realize their inherent benefits. This was going to encourage consumers to join the community. Local Energy Communities, as mentioned in the Clean Energy for All European package of the European Commission, were going to become an important pillar of the new energy system architecture. Until then, LEC planners lacked the tools to design LEC energy systems.

In Austria simulation of the distribution of LECs by enabling them to assess the technology options and related benefits and calculate an optimized LEC energy system design, was performed. Key technologies of LECs were the coupling of energy sectors (electricity, mobility and Hydrogen) and the integration of flexibilities. CLUE Austria demonstrated variety of LEC solutions through the integration of different types of system flexibilities in two demonstration sites. This deliverable presents all the activities and results performed in the CLUE Austria call.

2 ELABORATION OF SELECTED BUSINESS MODELS

Guidelines for RECs and CECs have been laid down in the Renewable Energy Directive and the Electricity Market Directive, both part of the Clean Energy for All European's Package. Some European Union Member states, such as Austria, have already transposed EU guidelines into national legislation, wherefore the foundation of RECs and CECs is legally possible. However, despite having legislation for RECs and CECs in place, the progress of diffusing these novel concepts needs to accelerate. To achieve acceleration, ECs need to be better integrated in the existing energy landscape, which would require increased cooperation of ECs and relevant stakeholders. However, for most stakeholders, certain economic benefits are a prerequisite for engaging with ECs. Therefore, the development of valuable business models for stakeholders in the field of ECs is of high importance. And, not only business models for stakeholders are needed, but also for ECs themselves. An issue is that according to the European Directives, the primary objective of ECs is not financial gain, but rather ecological or social community benefits. It is a fact, however, that a certain economic viability is essential for ECs and their participants. Concluding, in the near future, business models for ECs and their stakeholders need to be developed.

In order to be able to develop valuable business models it is necessary to have a complete picture of all stakeholders involved. Moreover, stakeholders' responsibilities as well as opportunities towards ECs need to be analysed in order to then derive appropriate (and realistically applicable) business models.

In the following, some stakeholders as well as their duties and opportunities (already possible or at least possible in the future) in Austria and according to Austrian legislation) are listed (note, that the lists do not claim to be complete):

- Electricity suppliers:
 - Obligations: do the imbalance settlement for individual participants of an EC, cover residual load; purchase surplus electricity.
 - Opportunities: expand their field of business towards offering services for ECs, such as operation, billing.
- Grid operators:
 - Obligations: grid access provision; data measurement; electricity allocation (static/dynamic distribution key); provide measured data to EC and participants via EDA-portal (Ger. *Elektronische Datenaustausch Plattform*)
 - Opportunities: conclude individual grid connection contracts with the EC; offer special tariffs for grid-friendly behaviour of ECs
- Energy services providers:
 - Obligations: None
 - Opportunities: offer services such as optimal planning, foundation, operation, billing; provide platform services for ECs
- Local authorities:
 - Obligations: None
 - Opportunities: help shape legal framework for ECs, aid information dissemination to gain citizens' trust → establishing ECs in a region strengthens the region and aids towards regional value creation
- Financing institutions:
 - Obligations: None
 - Opportunities: use ECs to expand their "green-investment" portfolio; marketing & establishing a good reputation, resulting in winning more clients

2.1 Electricity suppliers:

Electricity suppliers are seen as having disadvantages due to the roll-out of energy communities. This is the case because less electricity from a conventional supplier is needed when electricity is produced and consumed locally within the energy community. However, electricity suppliers – although not allowed to actively participate in energy communities according to the Austrian legislation – can offer services to the communities. An already established business case are contracting models, in which electricity suppliers offer to install (and often maintain) renewable electricity plants (e.g., PV systems) and either rent the plant or sell its generated electricity to offtaker(s). The rent model, called plant contracting, could also be established for energy communities, since the control power (Ger. *Verfügungsgewalt*) of the plant would remain in community hands, as envisaged in the Austrian legislation. Additionally, to this business case, other services can be offered to energy communities. These include planning and operation of the energy community (and renewable electricity plants) as well as accounting and billing services. Additionally and closely linked to the accounting/billing services, consulting concerning tariff model design (and accounting/billing services) within energy communities could be

offered. The tariff model design is currently limited to models for which an ex-ante allocation of energy flows by the grid operator, as currently executed for Austrian energy communities, is possible. This excludes actual peer-to-peer-trading pricing, such as the “delta pricing” method, for which not all trades would take place due to deviating prices for the sale and purchase of electricity. The “delta pricing” method, e.g., would allow to set the selling price for locally generated electricity within the community always higher compared to the individual grid feed-in price and the purchase price for this electricity lower compared to the individual electricity from the conventional supplier. This model could constitute a fair pricing method for energy communities, considering the free choice of electricity suppliers in Austria.

2.2 Energy service providers:

The engagement of energy service providers with ECs and vice versa can lead to a fruitful cooperation for both sides. Energy service providers are usually local actors having the trust of the citizens of the area of operation. This trust can significantly aid in establishing an EC with an appealing number of participants. Energy service providers can develop promising business models, by offering services such as optimal planning for the EC, managing the organisational processes regarding the EC foundation, operating the EC and do the billing based on the data provided by the DSO via EDA platform. Important for the details of the business model development would be that the cost for the services of the energy service provider does not exceed the revenues an EC can make, because otherwise the EC might refrain from contracting an energy service provider. However, since the services of an energy service provider do not rise proportionally with the number of participants, larger ECs are more likely to be able to afford services of an energy service provider. Over time, when services of an energy service provider have reached a certain degree of automation (f.e. platform service for the billing process), they can possibly reduce their cost of service and consequently win more customers.

2.3 Distribution grid operators:

In Austria, DSOs are regulated monopolies, wherefore the term “business model” might not be entirely suitable. However, the possibilities of DSOs shall also be discussed in this context. Currently, RECs are subject to reduced grid tariffs in Austria, without knowing whether RECs actually have a positive impact on the grid. Generally, it is not known how and if a roll-out of ECs at a large scale might impact the grid. Since it is highly unlikely that “grid-friendly-behaviour” and according measures will be manifested in legislation, DSOs might decide to take action on their own. Such action could for example be to offer special tariffs for ECs who operate in either a non-grid-burdening or even a grid-supporting manner. As an actual business model for the DSOs, the saved costs by offering special tariffs for ECs need to be greater than the alternative, namely conducting large investments in the grid infrastructure.

2.4 Local authorities:

Also, local authorities have their advantages when deciding to work together with ECs. Offering local support for the EC, local authorities could, in return, align their local activities (f.e. activities conducted in model regions, leader regions) and local (renewable energy) development plans with ECs. This could be a significant advantage for the region and facilitate efforts of local authorities.

2.5 Financing institutions:

Financing institutions are supposed to increase their portfolio regarding “green financing”. Nowadays, green financing goes beyond sole investments into renewable generation units. Another dimension of green financing would be to invest in infrastructure in the context of ECs. A hurdle thereby is the legal personality of the EC, because the easier the entry and exit of members (f.e. as in an association), the higher the risk for the financing institution. However, for the cases where risk is manageable, it can be beneficial for financing institutions to offer their services to EC. Not only the number of (green) investments could be increased, but also, due to the simultaneous increase in good reputation, new customers can be gained.

3 END CUSTOMER ACCEPTANCE AND PARTICIPATION

Since CLUE aims at developing tools for planning, operation and monitoring of Energy Communities (EC), not only stakeholder feedback of these tools is required, but also the view of the end users and their requirements on monitoring and operation of an EC needs to be considered. To ensure willingness to participate in an EC and acceptance of these tools and concepts also in future non-project-based ECs, the concerns and motives regarding ECs are researched within the Austrian testbeds.

In the Demo-Regions several activities to include the inhabitants of the regions were implemented. Not only households directly involved in the CLUE project, but also citizens living within the demo regions were informed and encouraged to give feedback to CLUE activities. Further, their perception of Energy Communities and processes within these communities were researched. In order to validate the findings from the small-sampled activities within the demo region, a broad survey among general Austrian population was conducted to provide deeper understanding on the framework conditions, which a successful Energy Community has to provide for its members.

The following table gives an overview about activities within Task 4.3:

Measure		Demosite	Aim
Initial Survey	March 2020	Gasen, Südburgenland	strengths and weaknesses of energy communities, interest in use cases
informational events	December 2019, December 2020, February 2021, June 2021, August 2021 July 2022	Gasen, Südburgenland	Inform citizens about project activities,

	September 2022		
Focus Group Discussions	July 2022, September 2022	Südburgenland	understand interest in relevant use cases; feedback on Business models,
Regional Surveys	April 22, June 2022,	Gasen, Südburgenland	understand motives and challenges regarding energy communities,
representative survey among Austrian population	May 2022	Austria	validate findings from demo regions

3.1 General perception of ECs in Austria and CLUE-Demo Regions

In total, the term “Energy Community” is somewhat known within the demo region already at project start in 2020. This could be due to information about the project CLUE presented in the demo-regions. However, the regional perception of energy communities may change over time as this concept gets more common in Austria. In the last project year (2022), citizens of the demo region were again asked about their interest to join an energy community. The qualitative talks showed that people still lack of information on Energy Communities, nevertheless the interest to become informed and join an Energy Community is high.

In the survey among Austrian population, this finding is confirmed. About 43 % have already heard about ECs, ca. 57 % did not know this term. Within the share of people being informed, the knowledge level is medium. This also relates to the results of the demo regions, that there is a high need for information on all aspects of ECs.

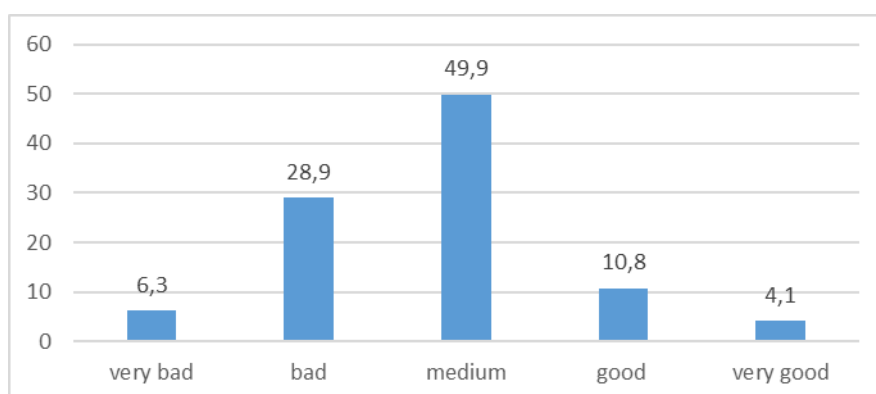

Figure 1: self-reported knowledge level of people familiar with EC (in %, n=539)

Despite the relatively low knowledge level on ECs, most respondents are interested into an EC membership. In the regional survey at project start, about 2/3 could imagine to join an EC, within Austrian population this share went up to 87 % (in 2022).

For any tool to be implemented within an EC, it is important, whether people trust the offering institution. An operation of an EC by a citizen’s association or cooperative achieved highest agreement in the demo region: 77% of respondents would agree to this

form of self-administration. About half of respondents (49%) also agree with the municipality or mayor as operator, 43% would approve energy supply companies operating the EC. An operation by housing companies or NGOs received lowest approval with 21% and 19% respectively. Results from the Austrian survey show a different picture: in general, energy supply companies and municipalities are the preferred operators for ECs, followed by private initiatives (see Figure 2).

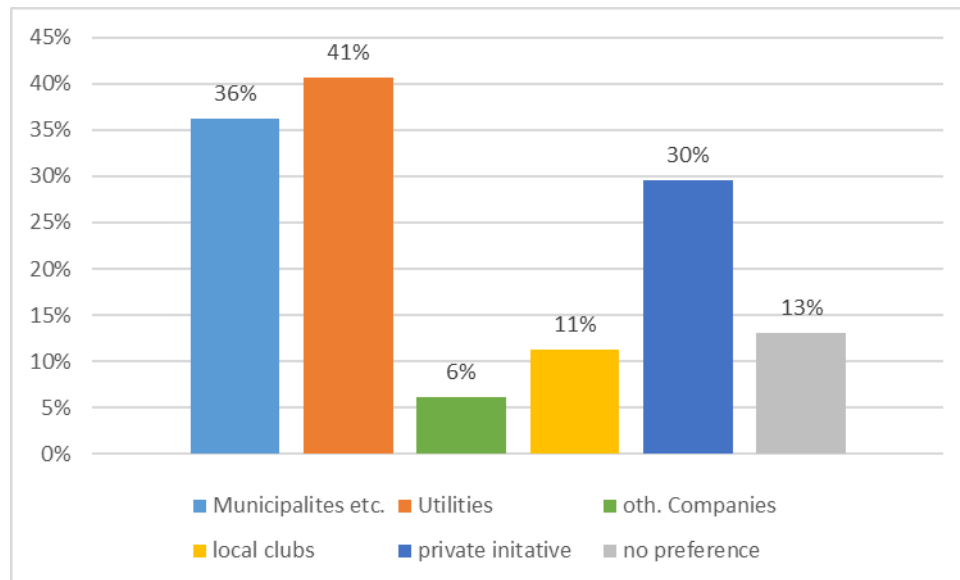

Figure 2: preference for operators of ECs in Austria (in %, multiple choice, n=1073)

There is already a broad body of literature available on motives and challenges regarding ECs. These motivations to join community energy projects seem to be rather heterogeneous (Bauwens & Devine-Wright, 2018; Dóci et al., 2015; Hicks & Ison, 2018) and complex, with various degrees of commitment of members (Bauwens & Devine-Wright, 2018).

According to most studies, some form of concern for the environment is a main motivation for citizens to join community energy projects (Conradie et al., 2021, 2021; Dóci et al., 2015; Kalkbrenner & Roosen, 2016; Schall, 2020). Soeiro and Dias (2020) describe concern about the environmental impact of traditional energy technologies as a leading motivation. Financial benefits appear as important incentives in nearly all studies (Boon & Dieperink, 2014; Conradie et al., 2021; Dóci et al., 2015; Hicks & Ison, 2018).

Accessible role models in the local communities who demonstrate environmentally conscious behaviour and membership in energy communities may encourage other community members as well to do so. Equally, providing information about such individuals may also have a motivating effect (Conradie et al., 2021; Martens, 2022). Social norms are reported to be almost as important as environmental awareness when joining community energy initiatives (Kalkbrenner & Roosen, 2016; Soeiro & Dias, 2020).

Community interactions and togetherness is a further important motive for citizens (Dóci et al., 2015; Schall, 2020; Soeiro & Dias, 2020). A further motivator is often the independence of energy producers (Boon & Dieperink, 2014; Soeiro & Dias, 2020) and the wish to take part in the energy transition (Soeiro & Dias, 2020).

Out of this literature results, nine central characteristics of ECs were chosen to conduct an importance-performance analysis (Martilla & James 1977). Respondents had to rate the perceived performance of these aspects in an EC on the one hand, the importance of these aspects for their own participation on the other hand. Figure 3 shows the results: based on the average rating of each dimension, the characteristics were assigned to four

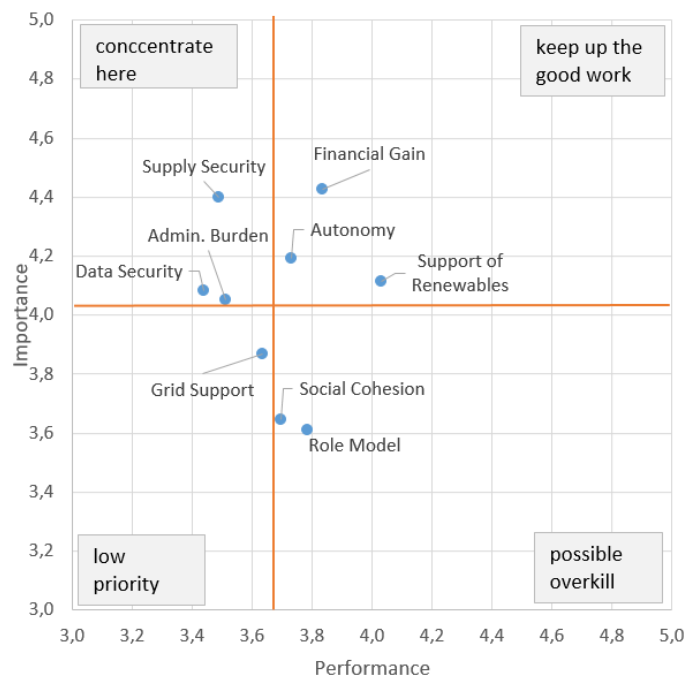

categories: “concentrate here” (with performance below average, importance above), “keep up the good work” (with performance and importance above average), “low priority” (with performance and importance below average”) and “possible overkill” (with performance above average, importance below). However, the results show the perception of potential members, not the reality of performance of ECs within these characteristics. This perception may be based on misunderstandings and prejudices, as the knowledge level is remaining low.

Figure 3: Importance-Performance Analysis on EC Characteristics (n=1073)

The section “keep up the good work” shows characteristics, which are quite important for the own membership, and are already perceived as fulfilled within an EC. Regarding autonomy and financial gain, there may be knowledge gaps, which lead to false expectations and frustration on the long term, as ECs mostly do not provide full energy autonomy and comparably low cost savings.

The aspects of supply security and data security need attention, as these are an important motivation for participation, but performance is perceived below average. Especially for supply security, people need more information about residual current handling. Administrative burden is also an important aspect: respondents are worried about high effort. This needs to be limited to a minimum to gain new members. Grid Support is of low priority for potential customers and should be of least priority in customer communication.

An interesting result is the section “possible overkill”. The two aspects regarding social benefit, which are often thematised in EC marketing, are of least importance for members. In addition, they are already perceived as fulfilled. Consequently, this is not a decisive criterion for joining an EC and information on these topics may meet lack of interest with customers.

3.2 Perception of CLUE-AT Use Cases

Use Case EV-Charging payment with community currency AND Community Currency Payment at 3rd parties: In the Burgenland Demo-Region, there is no clear preference for locally produced energy. Based on the feedback from regional survey and interview activities, we conclude, that inhabitants have limited willingness to pay higher prices for locally produced electricity. However, at public charging points, there is a demand for the information of the origin of the electricity. Charging with community produced energy is of interest, as well as an overview on own consumption and production and community consumption and production. Regarding payment with community currency, people are highly sceptical, as it is quite an abstract and new concept for most respondents.

However, in the testing phase, participants were educated about community currency and its handling and the idea of a regional currency to be used for regional purchases was very well received. The idea that the local creation of value by installing renewable energy resources (PV panels) could be expressed in the local energy currency “e-kWh” received a lot of positive feedback by the community.

The technical details on how the local energy currency was tokenized and transferred to the blockchain was of no particular interest to the participants, however clear instructions and a well developed user interface for the interactions in the Energy Account and in the Minerva blockchain wallet proved to be important. Interacting with digital currencies was a new experience for most (if not all) participants and the process needed considerable guidance from the project team was needed.

The feedback from the community, however, has been predominantly positive with people expressing interest to expand the utilization of the regional currency beyond the first test use case.

Use Case Community Battery Storage: at project start, the interest in a community storage system in the Gasen Region was high. During project, people in Gasen remain interested in the Storage System: informational events and tours to the storage were well attended. The desire for the product/service “battery storage purchase” or “battery storage use” is very high. Regarding such services, testusers would like to have transparent data on their own and the community’s storage use. Such data would also increase trust into the benefit of energy communities, at least in the CLUE demo.

Use Case Direct Load Control / Automatic Demand Response: inhabitants of the demo region show low interest for demand response of household appliances. Regarding large appliances (heat pump, e-boiler, e-car, battery storage) almost all owners of devices providing flexibility are interested in implementing demand response to their flexible loads (>80 % of respondents interested). Still, some people do not show more interest into demand response using household appliances than respondents without flexible loads.

Feedback from test users show, that there should be minimal or no restrictions in the daily life of the participants. The automatic demand response of household appliances is generally a more sensitive issue than e-boilers, or heat pumps etc. Only if a high financial advantage is expected the general user behaviour will be changed towards demand response. Testusers show highest acceptance of direct load control applications like heat pumps, e-boilers, e-cars and (central) battery storage systems, due to buffer times and less loss of comfort. The possible complexity and the (financial) purchase of demand-devices were identified as barriers for implementation. The results of the survey among Austrian population delivers a first insight into the question whether community membership enhances the willingness to accept load control. Within the survey, this use case was strongly simplified, as respondents were not informed on ECs and on the concept of load control. Therefore, the everyday metaphor of water supply and taking a shower was used to assess the willingness for load control and its connection to rising grid fees or investment costs.

Willingness to invest for capacity expansion: the belonging to a community, which takes care of its own supply, raises the willingness to invest in capacity expansion in comparison to the supply by an external third party significantly (Agreement to investment in capacity expansion rises from 61,5 % to 74.1 %, n=1073)

Willingness to accept load control: the belonging to a community slightly reduces the willingness to shift loads (from 58.9 % to 56.2 %) and the willingness to reduce load (from 61.7 % to 58.1 %). According to survey results, people would rather prefer to shift or reduce loads than pay for higher grid fees, when a third party is responsible for supply. When being in a community, they prefer to pay themselves for capacity expansion rather than reduce or shift loads. This results, however, has only limited transferability to the special case of ECs and further research is needed.

4 LEC TOOL KIT - ENERGY COMMUNITY PLANNING

4.1 Scope and Introduction of an Energy Community Planning Tool Approach

As stated in the project proposal, one of the main goals was to develop a LEC tool kit, which in terms of technology proof-of-concepts with the goal to provide a system environment that can be validated by stakeholders. With the BIFROST tool SIEMENS had already a versatile tool suite available, to provide a basis for the development of the LEC tool kit.

“BIFROST is a narrative Smart Grid simulation tool for exploring, building, and presenting stories about settlements, communities and quarters pushing to adapt to the climate crisis. It offers simulation orchestration and creative tools to quickly explore variegated scenarios, with the ultimate goals of reducing complexity and presenting technological solutions. It fosters engagement in decision processes and enables integrative discussions across a range of expertise levels. With this workshop, we want to introduce BIFROST, show some successfully realized projects and applications, and give the participants the chance to build and explore their own virtual community.” (Hauer, et al., 2021)

4.1.1 Potential Use Cases for a LEC Tool Kit

The following parts of the LEC tool kit are (according to the proposal) under investigation and the validated results will form the basis for the economically viable solutions that must be developed following the project CLUE in the form of productive solutions:

- Planning tool (Planning of future LECs with integration of renewable energy sources, storage, customers, integration of electric mobility, and power-to-heat applications),
- Monitoring and information tools (These tools provide capabilities to have a real-time overview about the energy flow within the community),
- Operation tool (It is a fully-automated tool for operators of LECs).

During the discussions and initial workshops, the vision of usage phases of a potential LEC tool kit based on BIFROST was defined with more precision and was formulated in form of four phases of potential usage:

0. Tool for communicating about ECs
→ Information Phase
1. Planning tool
→ Planning Phase
2. Tool to support the operation of EC
→ Operation Phase
3. Tool to also offer suggestions for improving the operation of ECs ...
→ Enhancement / Improvement Phase

In the following these phases are explained in more detail

4.1.1.0 Information Phase

In this phase, an interested group of people will be shown what an energy community is, what possibilities it offers, and what benefits they can derive from it. This should be accessible to a broad user group who may not have much or any knowledge about the topic of energy



Figure 4: Using BIFROST to explain the concept of an energy community

BIFROST is here used to give a good overview and allows to answer questions interactively. The tool is here operated by an expert, who than later can help a potential community in their planning. When BIFROST is used in this following phase, the UI is already familiar to the community members.

4.1.1.1 Planning Phase

After the Information Phase a community may forms and want's to decide, what goal they want to achieve, which assets are needed for this, which operation strategies they should follow, etc.

The following steps are taken in the planning phase:

1. modelling settlement / EC area
2. supplement (opt.) data
3. determine parameters / EC characteristics to be studied
4. evaluation and presentation of the results
5. (optional) modification of the modelling of settlement / EC area
6. repeat steps 2. to 4.

4.1.1.1.1 Modeling + Adding Data

In the first step, the settlement is modelled with its main participants. Depending on the data, this may be more or less detailed. Neighbouring but non-participating parties can also be specified.

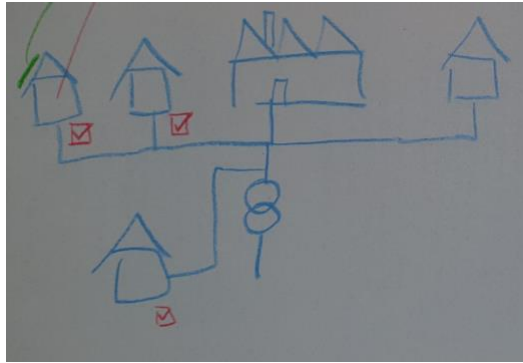

Figure 5: Sketch of the modelled settlement

It should be possible to already have (internal) data available by default, but also to expand data if available (e.g., if measurement data is available because you already had a smart meter, have data from your own PV, etc.), see Figure 6:

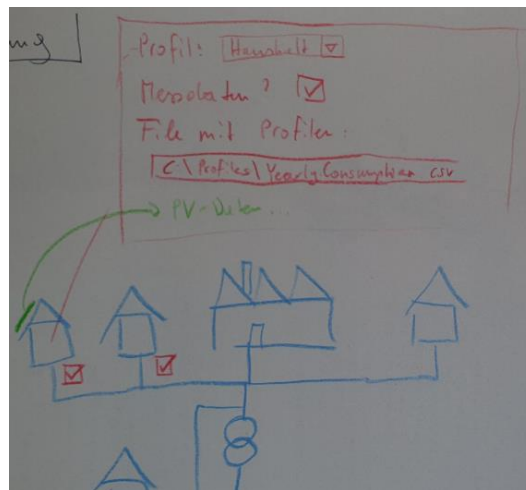

Figure 6: Adding data to the modelled settlement

4.1.1.1.2 Setting parameters

You can then choose from a pool of different settings for the operation of the community, independent of the settlement creation. It should also be possible to compare different variants or scenarios against each other, see Figure 7:

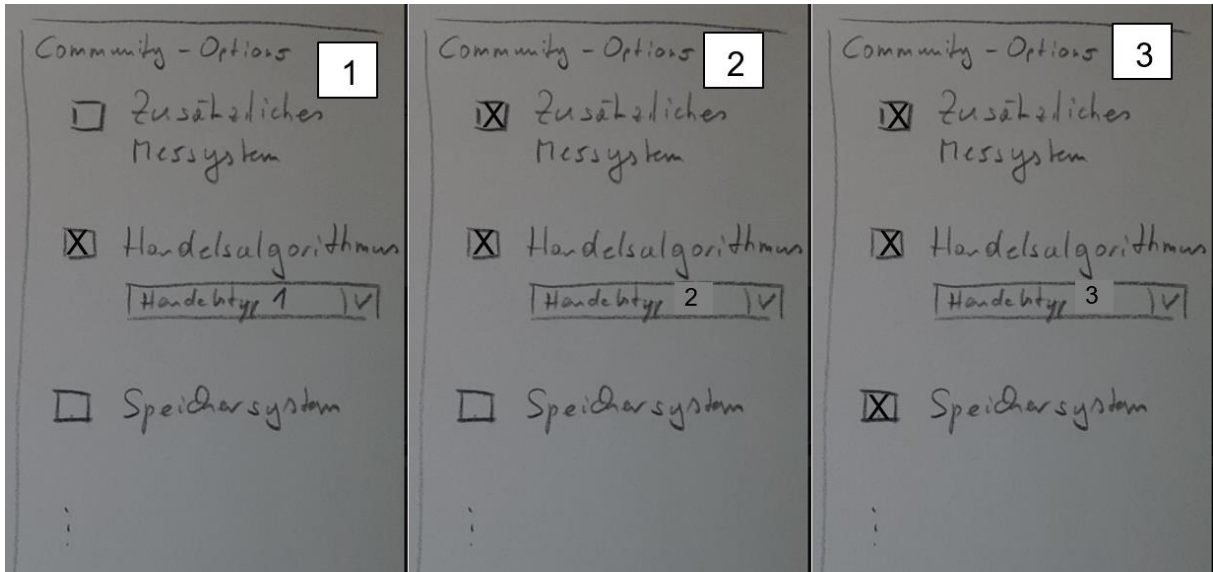

Figure 7: Define different variants

Here, too, a default preselection may be possible from the beginning.

4.1.1.1.3 Evaluation and presentation

Through the various options, the active modules for the simulation are then activated and, on the one hand, one can view the live operation in the simulation (for certain critical days: little PV, a lot of PV, weekday, Sunday) in order to get to know how the community works (analogous to the communication mode).

On the other hand, an evaluation should also take place that describes how the individual variants affect the participants, see Figure 8:

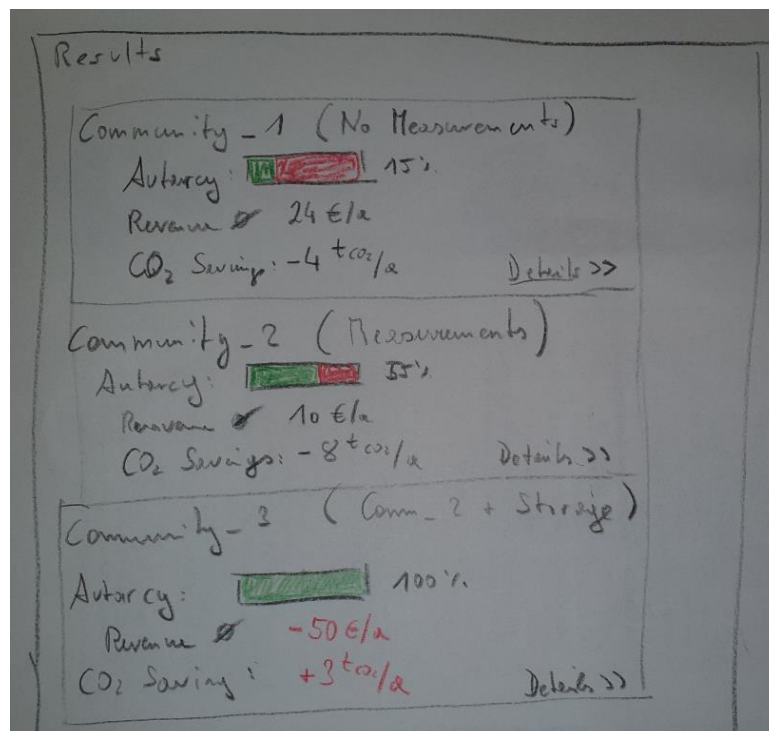

Figure 8: Idea for representation of the results and comparison of different variants or scenarios

Here, calculations e.g., a whole year's profile must be carried out and evaluated in the background.

4.1.1.2 Operation Phase

In this phase, the focus is on the presentation of the current operation of the EC with possibilities to intervene in the operation of the EC, e.g. by having the possibility to set options.

Within CLUE, there were identified three different modes for presenting the operation of the EC:

- View for EC participants
- View for EC operators
- (optional) View for the Maintainer of the EC
- View for external parties (for advertisement or presentation of the performance of the EC)

4.1.1.2.1 View for EC participants and EC operators

There is maybe the need for different views for the single participants because of access rights to the data and data protection? E.g. that not all data of all clients can be viewed by all others. Also important is this regarding the set options!

Possible data and events, which would be interesting to see from such an operation tool are

- EC has generated a lot of energy as surplus
- Storage system was never charged
- Changes in the active algorithm

- Long downtimes during data transmission losses (what happened there)?

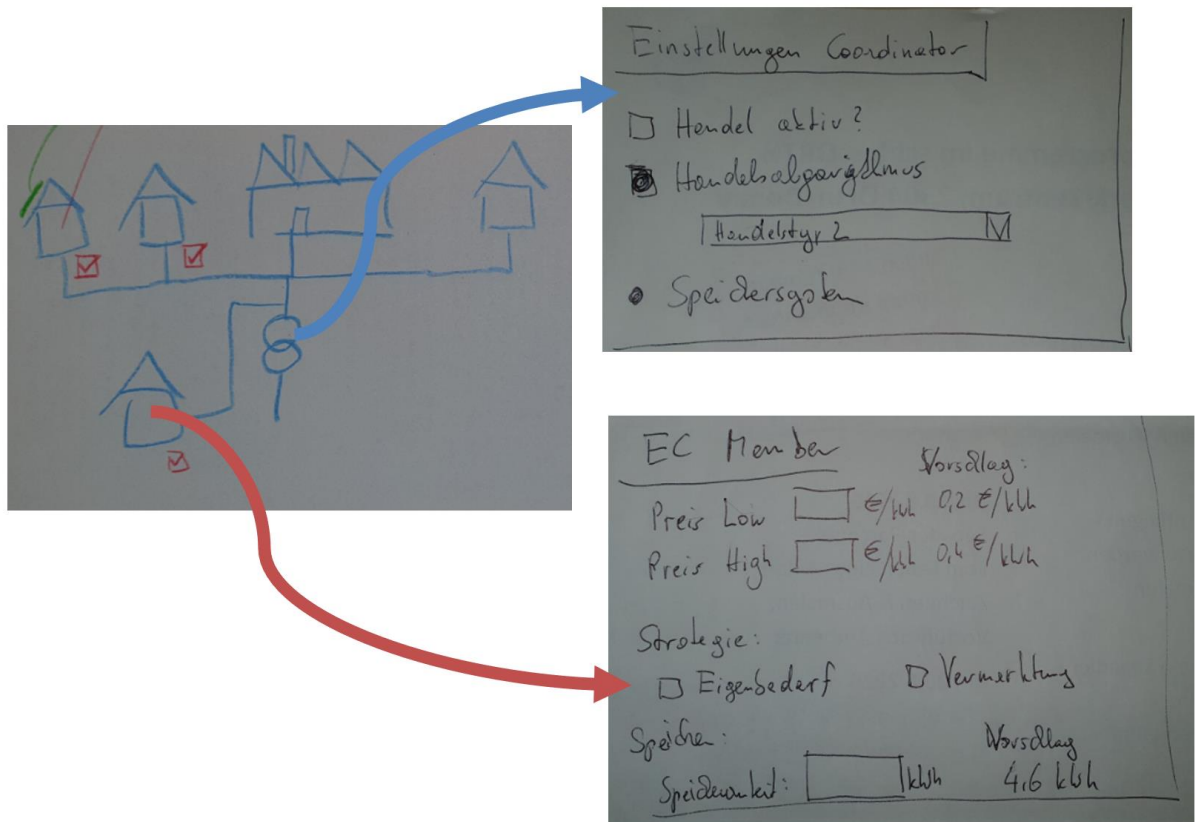

Figure 9: Example of what data and Settings are visible for members and operators of an EC

4.1.1.2.2 View for presentation

The aim is to display global parameters that are not relevant for data protection on a surface as well as a representation of the state of the EC (e.g. via highlighting).

This should make it possible to show the community to a wider audience for presentation and advertising purposes.



Figure 10: Dashboard with non-sensitive information to show externally

4.1.1.3 Enhancement / Improvement Phase

In this phase, the community is already in operation maybe for a longer time. The goal of the tool, besides the normal operation mode, should be to make proposals to the community, so it can better achieve certain goals, e.g.:

- Increasing self-sufficiency: Introduction of storage system (+ associated storage size + possible costs + how this affects the cost structure of the EC + impact on CO2 footprint, ...)
- Change community structure: Point out that too much load or infeed is present in the current community. Provide maybe data to know, which kind of new member should be added to the community.



Figure 11: Proposal of the LEC Tool Kit to improve the community operation

4.1.2 User Story for an Energy Community Planning Tool

Out of the four potential use cases for a LEC Tool Kit (see section “4.1.1 Potential Use Cases for a LEC Tool Kit”) in an early phase of the project was decided to only look on the “Planning Phase” in more detail. The “Information Phase” was already implemented in BIFROST and due to missing operational data, the next phases were defined as simply too far in the future to develop a meaningful demonstrator here. Therefore, it was decided to develop a prototype for an Energy Community Planning Tool as part of the LEC Tool Kit.

To have a guideline for specifying the requirements for this EC Planning Tool, a user story was defined, in which the planning process was illustrated. Based on this user story the architecture and requirements for the EC Planning Tool were derived.

The story is titled “Investigating Optimization Results”. In it the planning stakeholders of an energy community want to understand, why the optimizer has chosen particular setting for a storage operation for a future community storage system. The tool itself is operated by a planning expert, who is working with the community members together. The aim of this process is that every member of the community understands the results and is willing to participate to an investment for this community storage system.

The user story in short form

1. Set up of the settlement (Energy Community) and provide data
2. Choose different scenarios of EC operation to be investigated, e.g.

- a. Trading algorithm to be used
- b. Storage system integration (yes / no)
- c. Additional PV installation (yes / no)
3. Perform calculations / optimization based on annual profiles
4. Compare results based on KPIs
5. Select a specific scenario
6. Export results to BIFROST for this specific scenario (settings, profiles)
7. Investigate results based on 24h profiles (maybe change settings for type of day, e.g. day in summer vs. day in winter, sunny day vs. cloudy day)
8. (OPTIONAL) change settings, see, what's happening

This user story was presented within the project consortium and to external interested experts in form of a "click-dummy". In the following picture series should depict the single stages in this planning process considered in this user story:

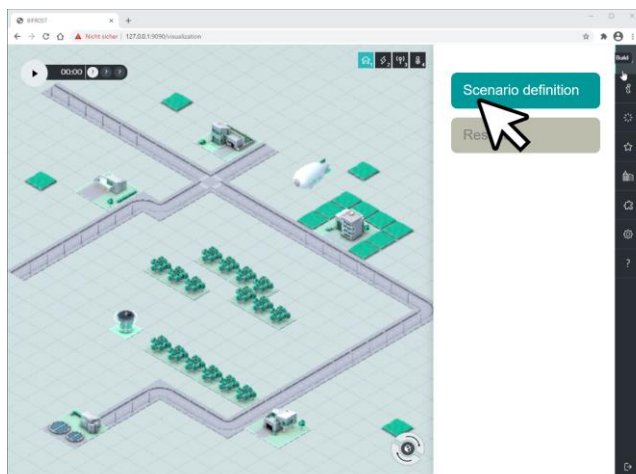

Figure 12: After defining the EC, scenarios to be investigated are defined

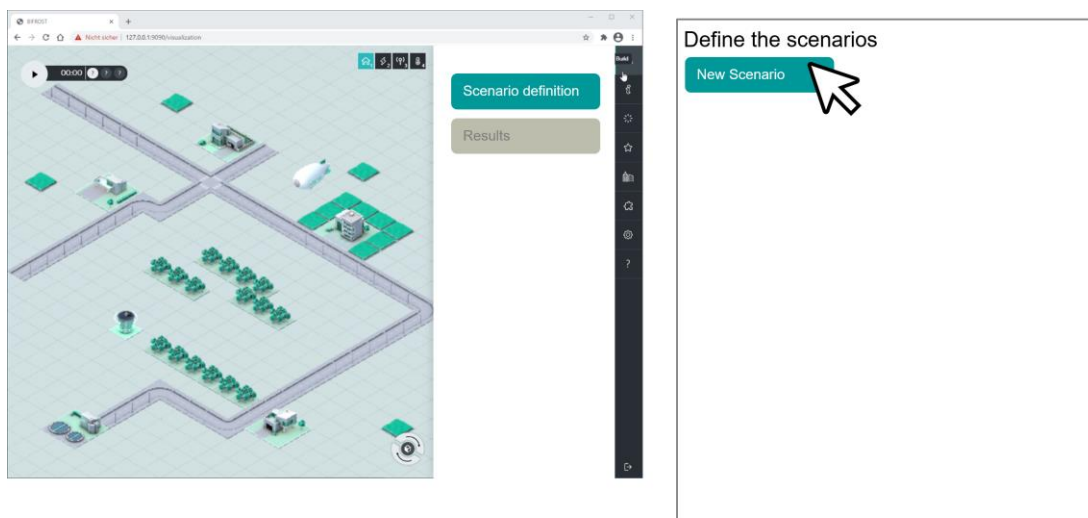

Figure 13: Different scenarios can be added in a separate UI

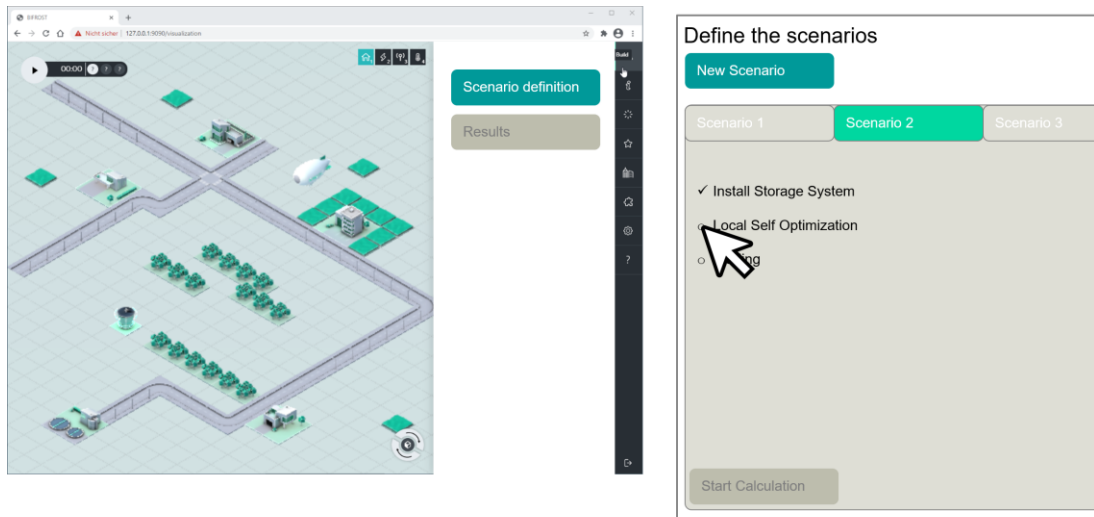

Figure 14: For each scenario different options can be investigated

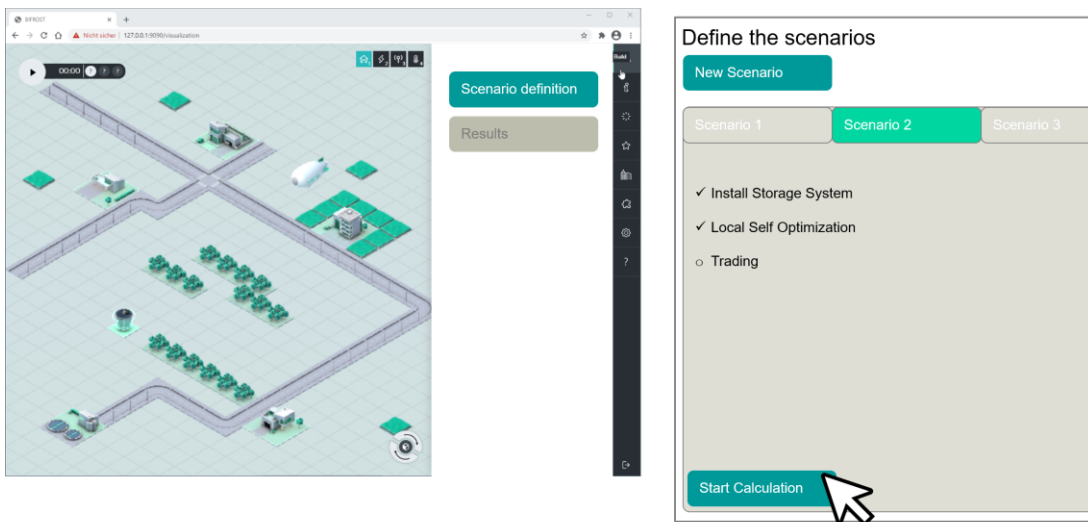

Figure 15: After the definition phase, for all scenarios the needed calculations are made

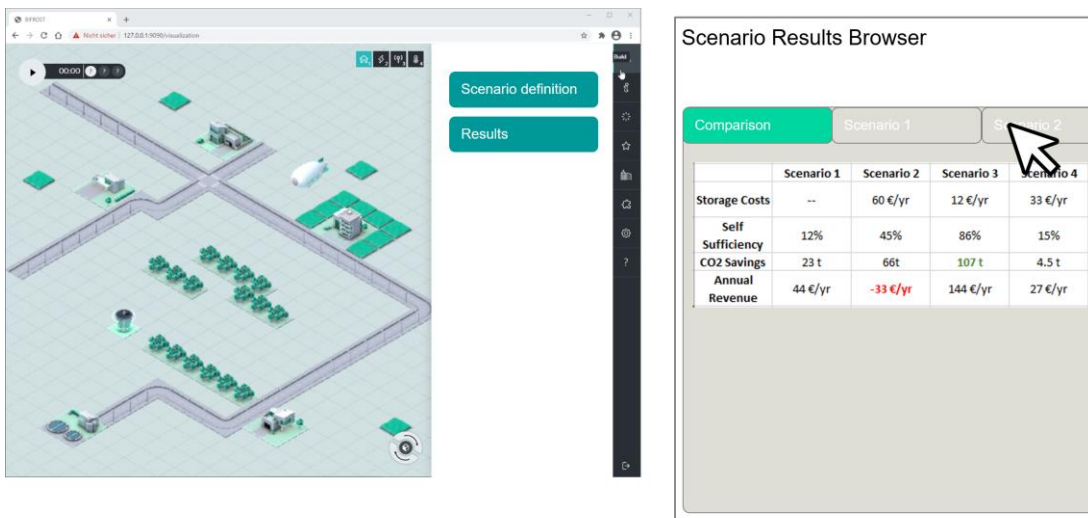

Figure 16: The results are presented in form of a short summary, based on performance on different KPIs, which represent different goals of the community operation.

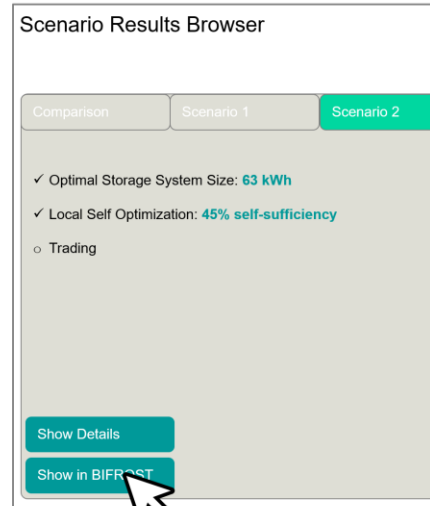
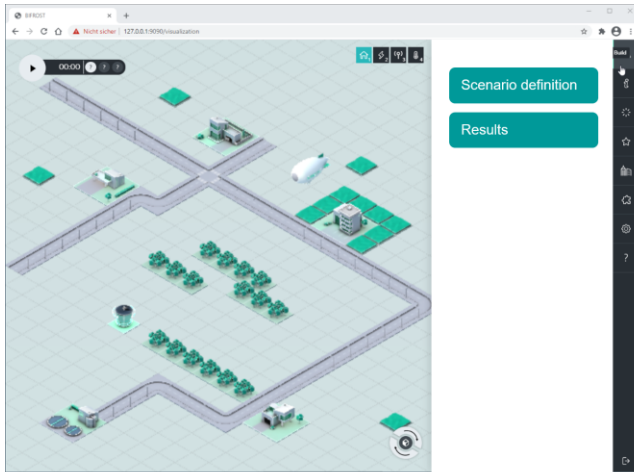

Figure 17: Now the data can be further investigated in the BIFROST UI

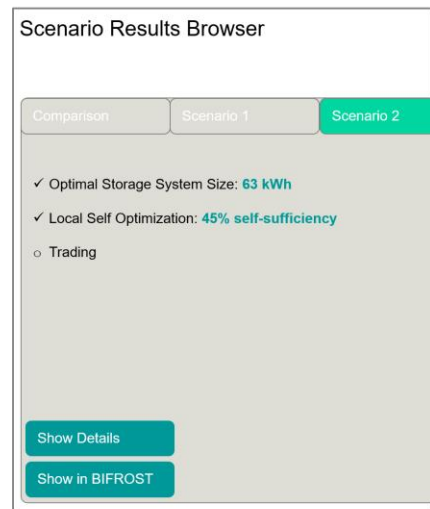
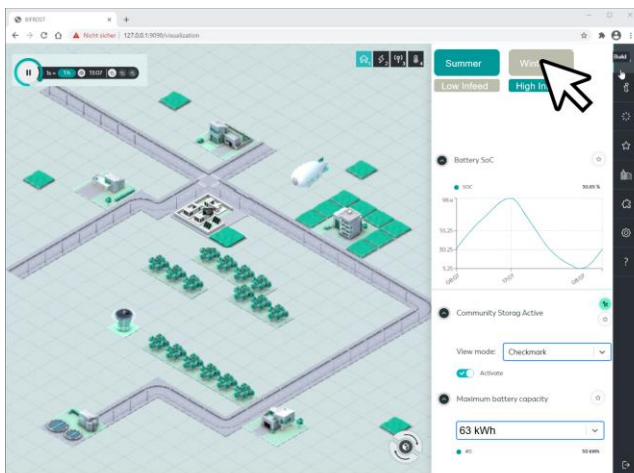

Figure 18: Here the performance of different assets can be visualized e.g., the storage system

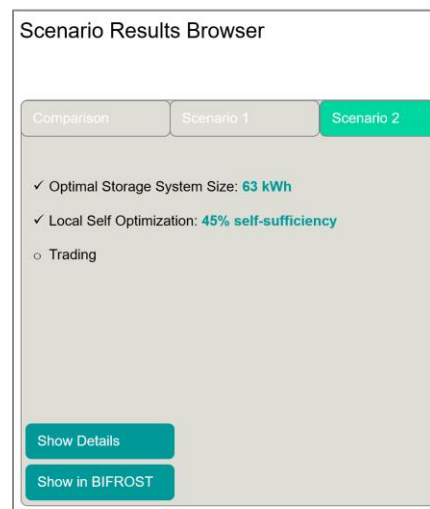
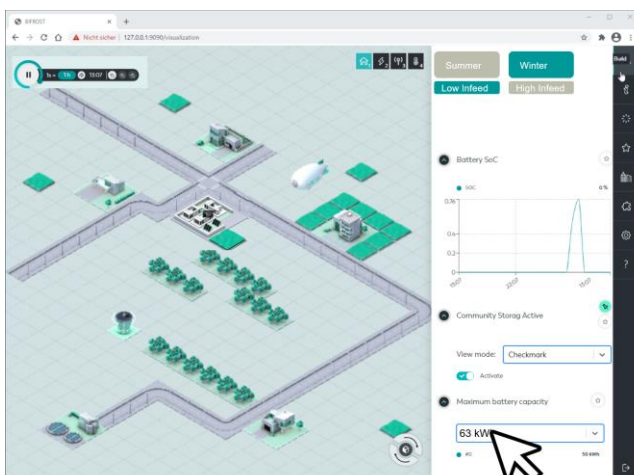

Figure 19: Also changes can be made on the calculations be redone

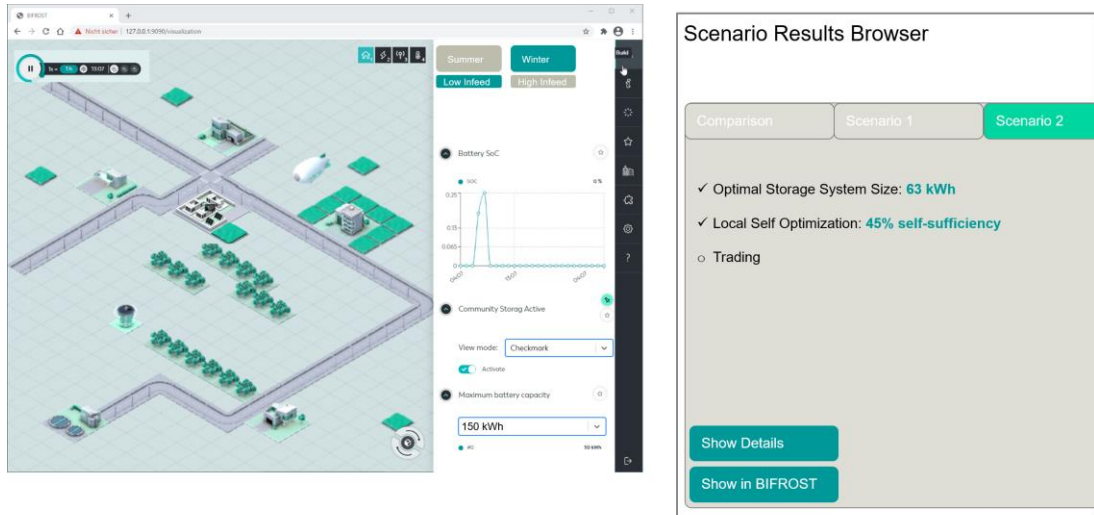

Figure 20: In this example it is shown that a higher capacity of the storage system has only a minor effect on the community performance, so the investment in this bigger storage system will not pay off

4.2 Architecture and Components

Based on the above stated considerations the requirements and the architecture for the Energy Community Planning Tool were derived. Figure 21 gives an overview over the single components and the proposed workflow:

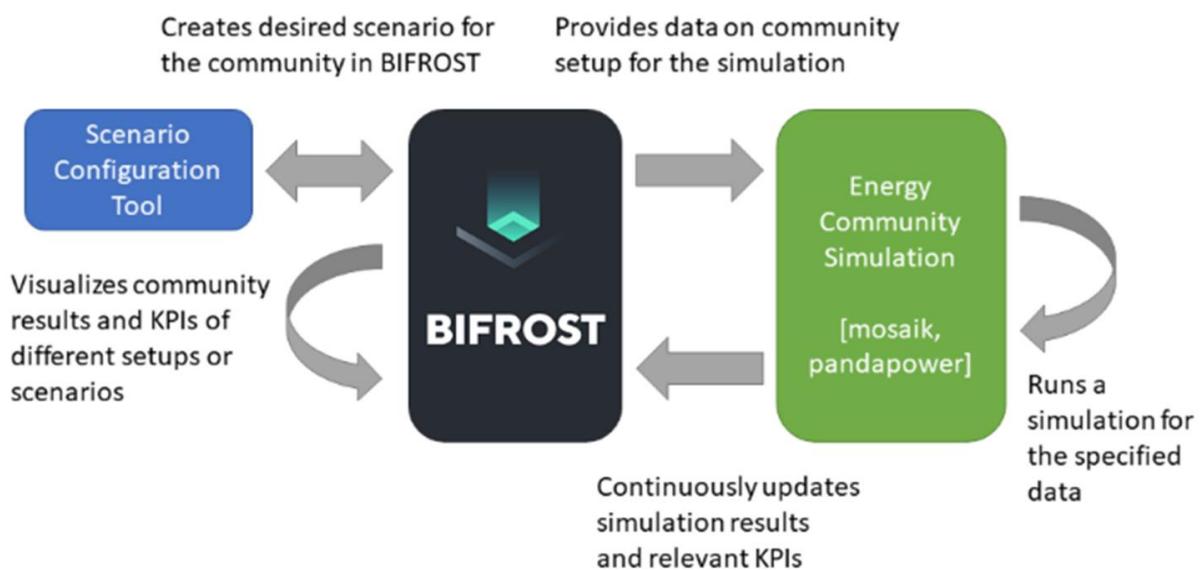

Figure 21: Overview of workflow using CLUE toolset for local energy communities.

The aim of the implemented planning approach is to give users a simple and low-threshold possibility to explore ECs. This planning approach was implemented as a prototype within the project and consists of four repetitive steps. It starts with the design of the settlement in BIFROST. Here, users have the opportunity to create an individual image of a possible EC or one that is already in operation. For this purpose, BIFROST provides numerous 3D models of buildings, such as single-family homes, farms, commercial or municipal buildings. These can be freely placed on a grid surface. BIFROST offers the possibility to map the grid topology of the electricity grid for the low and medium voltage level, communication networks as well as a thermal grid for local and

district heating. For local ECs, only the expansion of the low-voltage level is currently relevant. However, other technologies could be integrated in the future. For example, the medium-voltage level could be used to model regional ECs, or the thermal grid for a sector coupling between electricity and heat.

4.3 This workflow using the planning and evaluation tools has been developed and improved throughout the CLUE project. The configuration, simulation and visualisation of the simulation workflow are loosely coupled and can also be used independently of one another. Together they provide a toolset allowing for beautiful, visual storytelling for energy communities as well as a scientific evaluations different energy community scenarios. The Scenario Configuration Tool (later also named External Config Tool, see section “4.6 External Config Tool”) was a development from TU Wien. The Energy Community Simulation (see section “4.3 Simulation Backend”) was implemented by AIT. SIEMENS adopted the BIFROST tool (see “4.4 BIFROST – Adoptions for LEC Tool Kit Application

Out of the requirements for the EC Planning Tool some adoptions of BIFROST derived, which were introduced in the release version “SINDRI”. In the following some of these changes are summarized.

One of the biggest changes was the development of a complete new simulation engine and introduction of a Data Core.

Technology perspective: The new Common Simulation Core (simulation example)

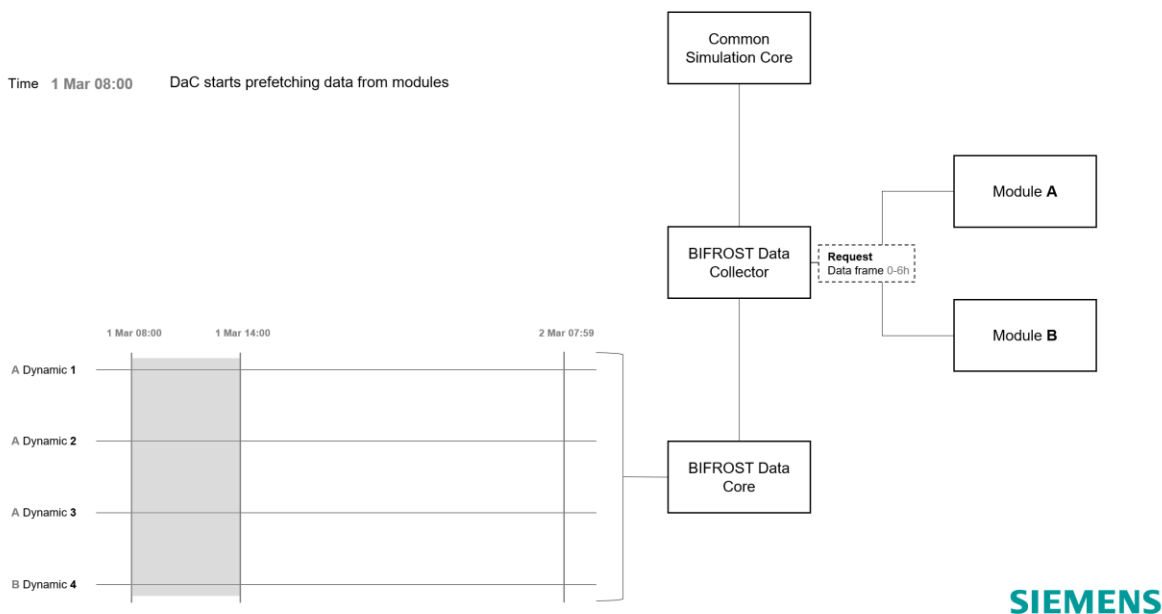

Figure 26: Technology perspective: Prefetch of simulation data

BIFROST should be enhanced to work with complete time series instead of single time simulations. The simulation data is provided by the modules in a fast way and is stored within BIFROST in a separate data base, see Figure 26.

To replay this data in the UI, single data points are later fetched from the data base and used, to show system states, see Figure 27

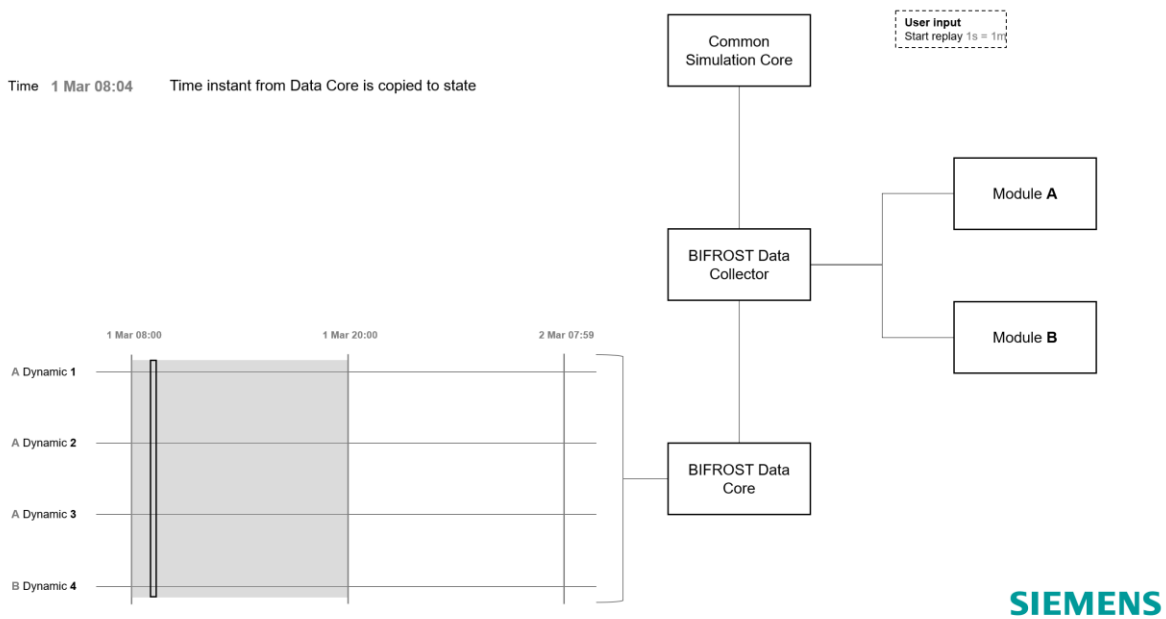

Figure 27: Technology perspective: Replay of data based on already made simulations

This technology perspective was implemented and realized in an adapted BIFROST UI, see Figure 28

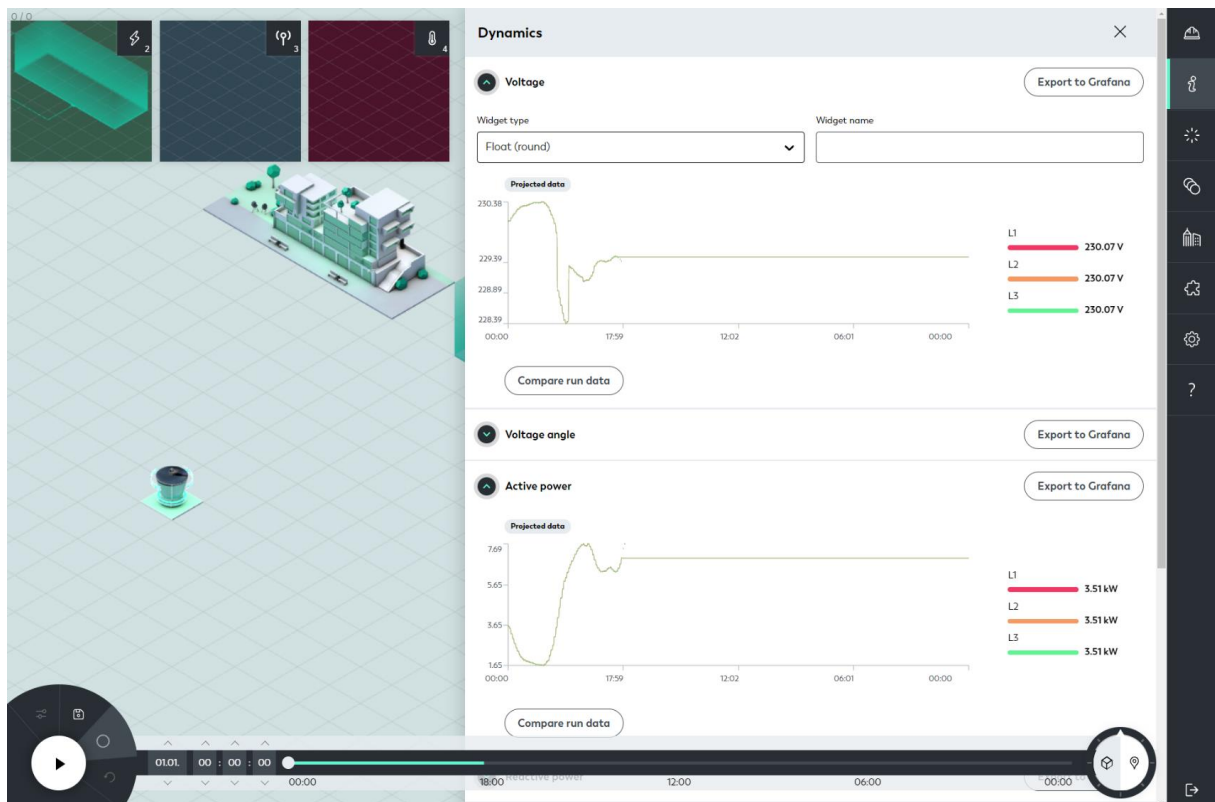

Figure 28: Realisation of the technology perspective of prefetching and replaying of simulation data

The potential operation mode (see section "4.1.1.2 Operation Phase"), despite not planned to be realized in CLUE, rose the question for a more convenient way to allocate real world data points and object to schematic elements of the BIFROST UI.

The corresponding technology perspective is shown in Figure 29.

Technology perspective: Geospatial relations 1

Challenge: maintain a consistent user experience across simulation and operation scenarios without sacrificing the BIFROST canvas UI or edging too close to GIS tools.

Proposal 1: Scenario selection and map layer

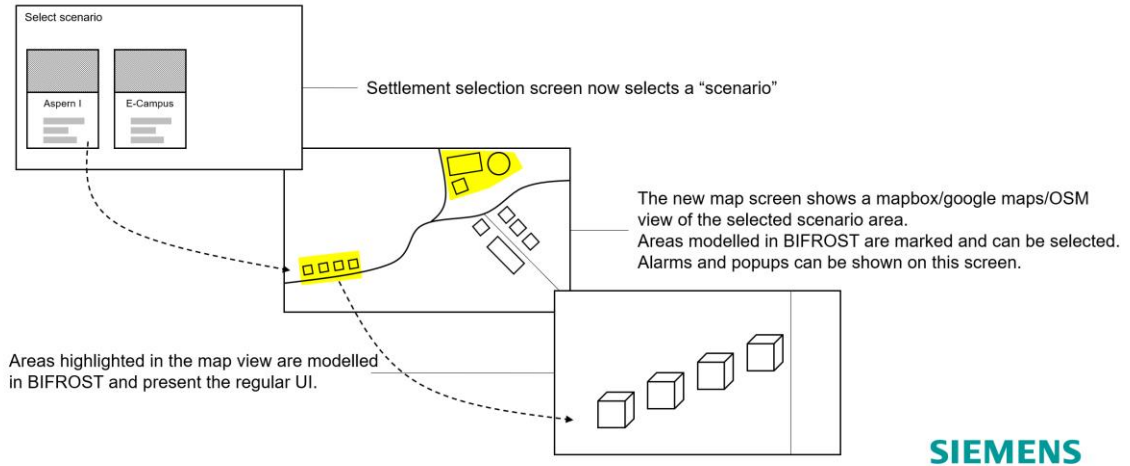

Figure 29: Technology perspective: Geospatial relations of whole settlement areas

The proposed solution over using a map to define an area of interest was than implemented, see Figure 30:

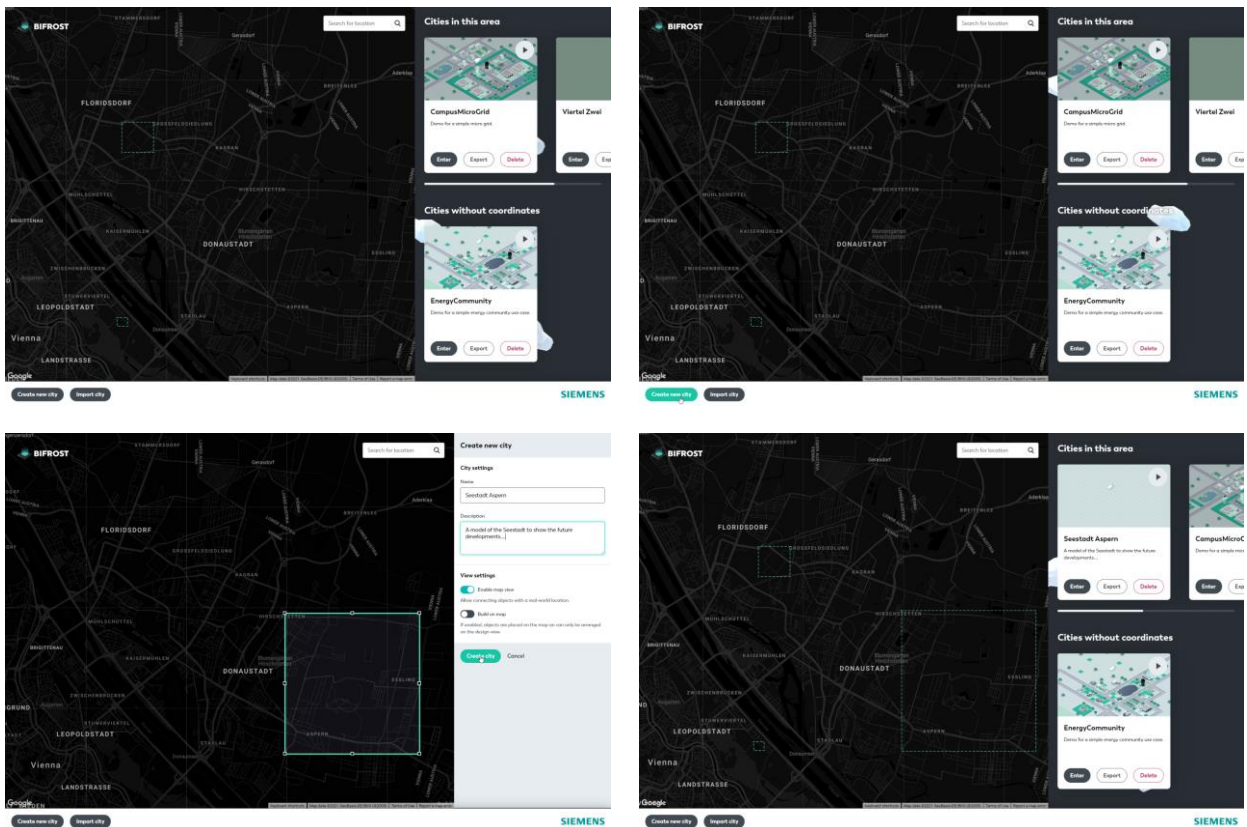

Figure 30: from top left to bottom right: Definition of a new settlement based on entering data via a map

When working within the settlement (representation of the EC) there has to be also a way to allocate certain elements of the schematic view with elements in the real world. The developed technology perspective is shown in Figure 31, the realisation shows Figure 32:

Technology perspective: Geospatial relations 2

Challenge: maintain a consistent user experience across simulation and operation scenarios without sacrificing the BIFROST canvas UI or edging too close to GIS tools.

Proposal 2: Map relation inlay

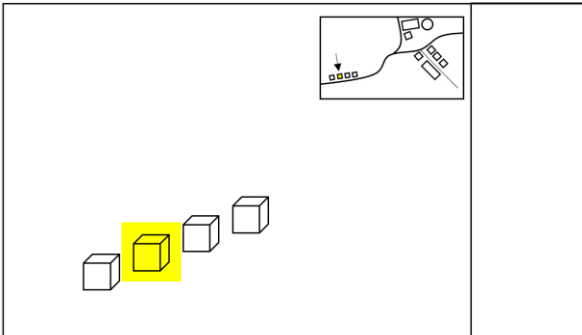

Show a map inlay which highlights the selected object on the BIFROST canvas with the map equivalent. This could be used for engineering purposes as well. There is a danger of creating a disconnect between the actual georelations and the BIFROST projection.



Figure 31: Technology perspective: Geospatial relations within settlement areas

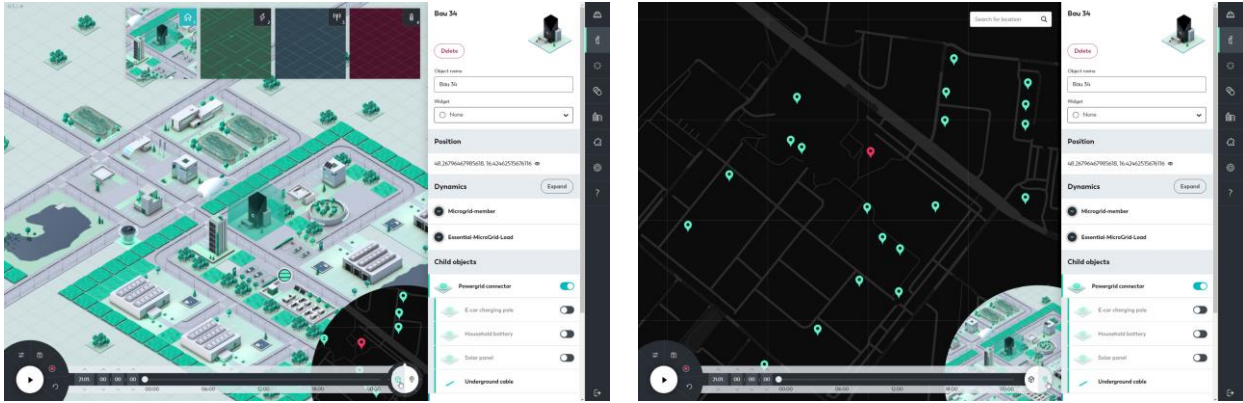

Figure 32: Allocation of elements of the schematic view to elements in the map

Besides this changes also some expansions for possible domains for simulation and modelling of ECs were introduced. Figure 33 gives a summary.

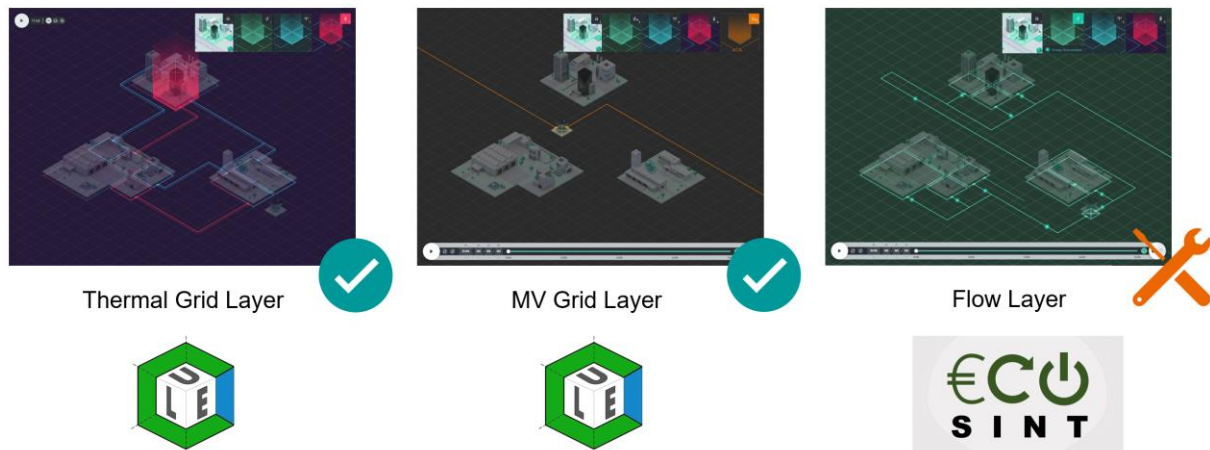

Figure 33: Overview of new domain layers in BIFROST

After CLUE in BIFROST also a thermal grid can be modelled. For ECs also the medium voltage layer can be considered. First ideas for a “flow layer”, to visualize flows within an energy community (like energy between participants or their cash flows) were developed. The implementation was not finished within the CLUE project, but is now done in the follow up project “ECOSINT”.

All these developments were directly derived out of the initial discussions and identified requirements for the LEC Tool Kit. Based on this new BIFROST release SINDRI, the planning tool approach was implemented.

4.4 BIFROST – mosaic Coupling

The CLUE mosaik Coupler is Bifrost-module which is the interface between BIFROST and the mosaik-simulation tool.

On the init call, a connection check to the mosaik-influx database is run and the parameters of the current BIFROST simulation run (date, start, end, dynamic configuration) are sent via REST to the mosaik-simulation. After that, the mosaik-simulation is started and runs asynchronously in the background.

While the module is in its update-cycle it requests the current simulation-progress. If the progress is sufficient, it requests a data-block from the mosaik-influx database. This data is parsed and written to BIFROST as fast as possible. This continues until the BIFROST simulation run is finished. If no data is received for 10 tries, the mosaik-simulation is stopped, and the module expects a new run to work properly again.

4.5 “) to meet the requirements for the Planning Tool approach was integrating the single components (see section “4.6 BIFROST – Adoptions for LEC Tool Kit Application

Out of the requirements for the EC Planning Tool some adoptions of BIFROST derived, which were introduced in the release version “SINDRI”. In the following some of these changes are summarized.

One of the biggest changes was the development of a complete new simulation engine and introduction of a Data Core.

Technology perspective: The new Common Simulation Core (simulation example)

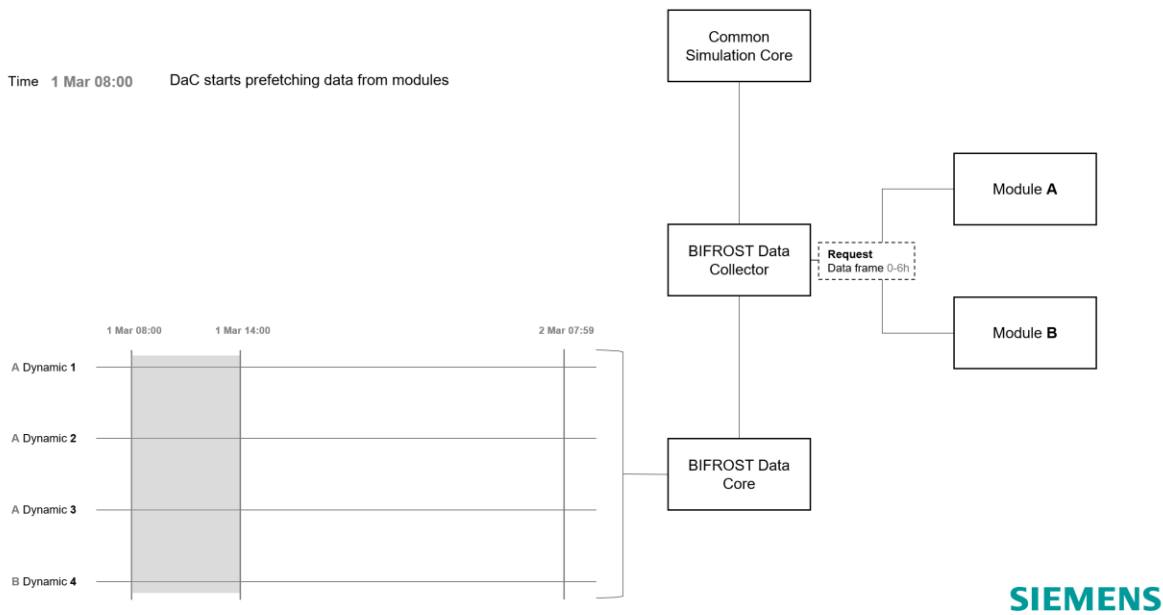

Figure 26: Technology perspective: Prefetch of simulation data

BIFROST should be enhanced to work with complete time series instead of single time simulations. The simulation data is provided by the modules in a fast way and is stored within BIFROST in a separate data base, see Figure 26.

To replay this data in the UI, single data points are later fetched from the data base and used, to show system states, see Figure 27

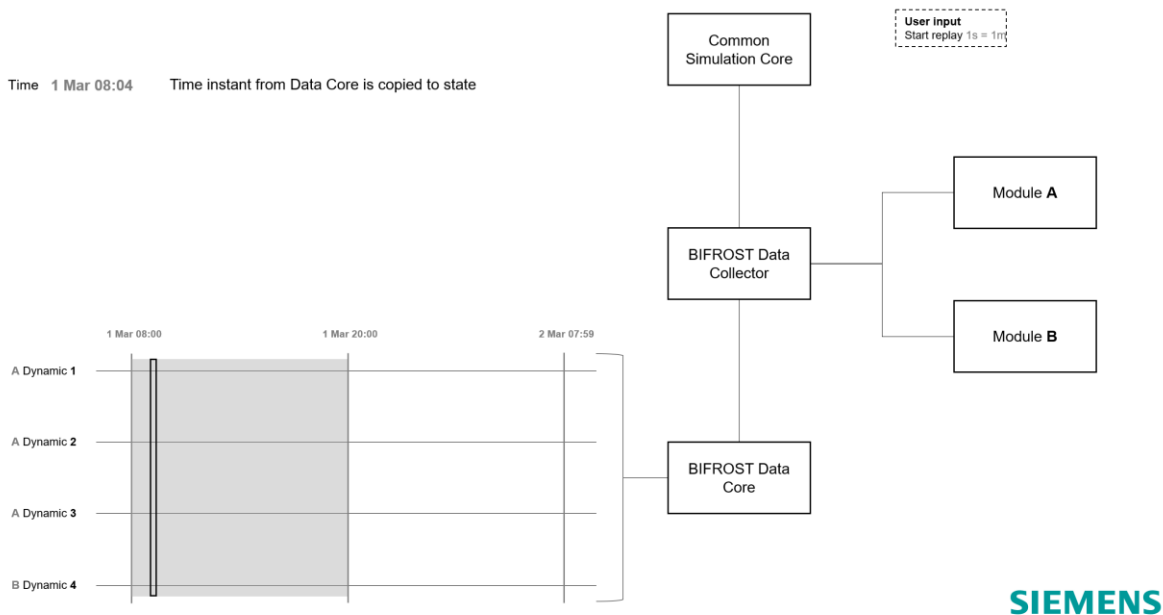

Figure 27: Technology perspective: Replay of data based on already made simulations

This technology perspective was implemented and realized in an adapted BIFROST UI, see Figure 28

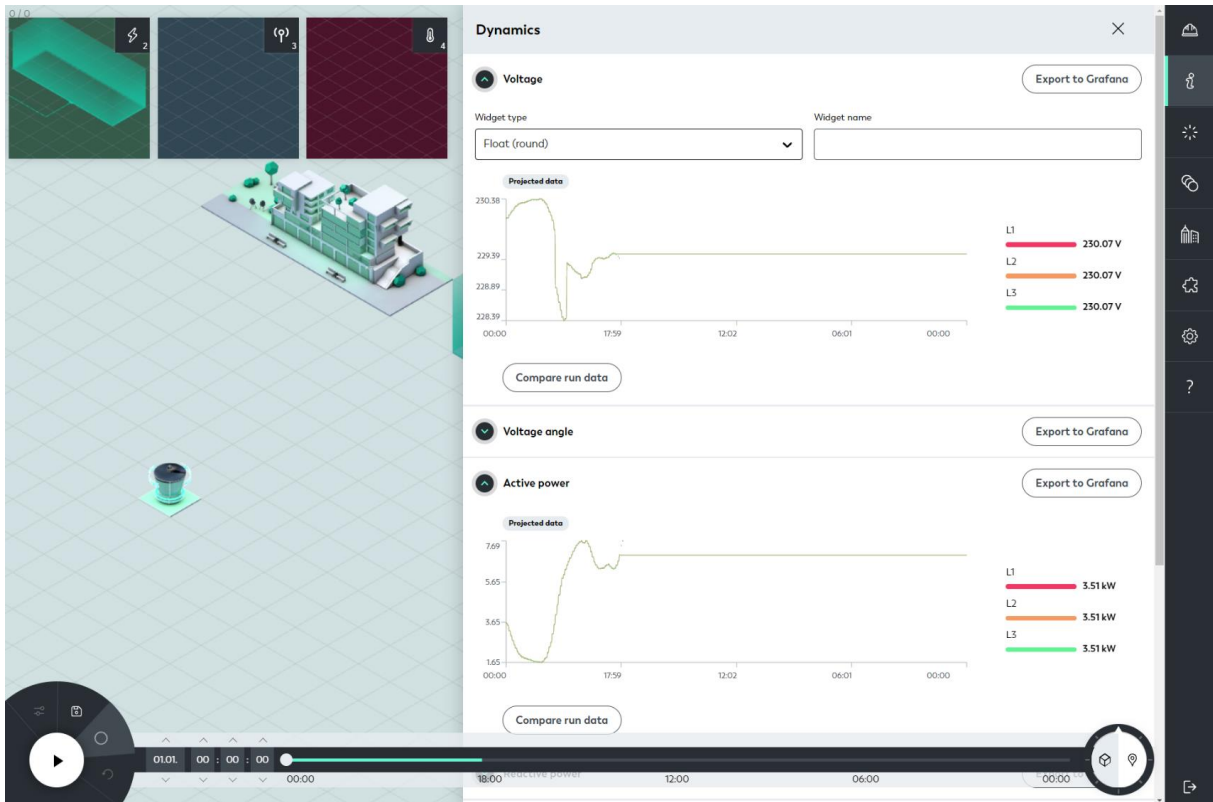

Figure 28: Realisation of the technology perspective of prefetching and replaying of simulation data

The potential operation mode (see section “4.1.1.2 Operation Phase”), despite not planned to be realized in CLUE, rose the question for a more convenient way to allocate real world data points and object to schematic elements of the BIFROST UI.

The corresponding technology perspective is shown in Figure 29.

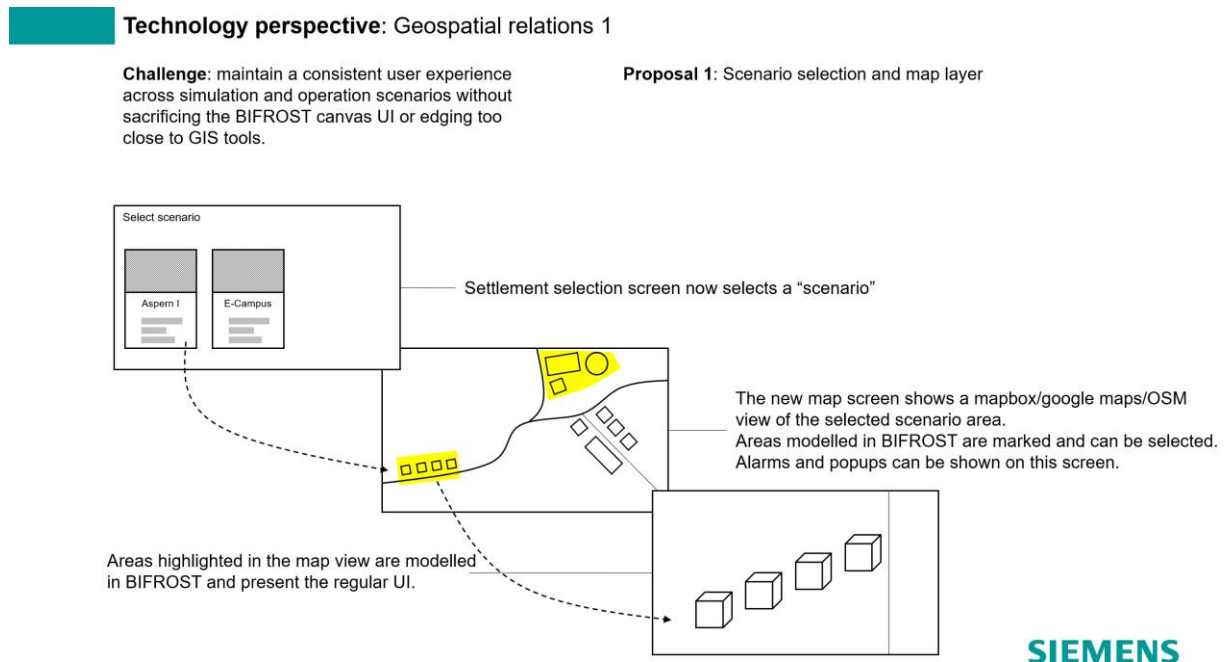

Figure 29: Technology perspective: Geospatial relations of whole settlement areas

The proposed solution over using a map to define an area of interest was than implemented, see Figure 30:

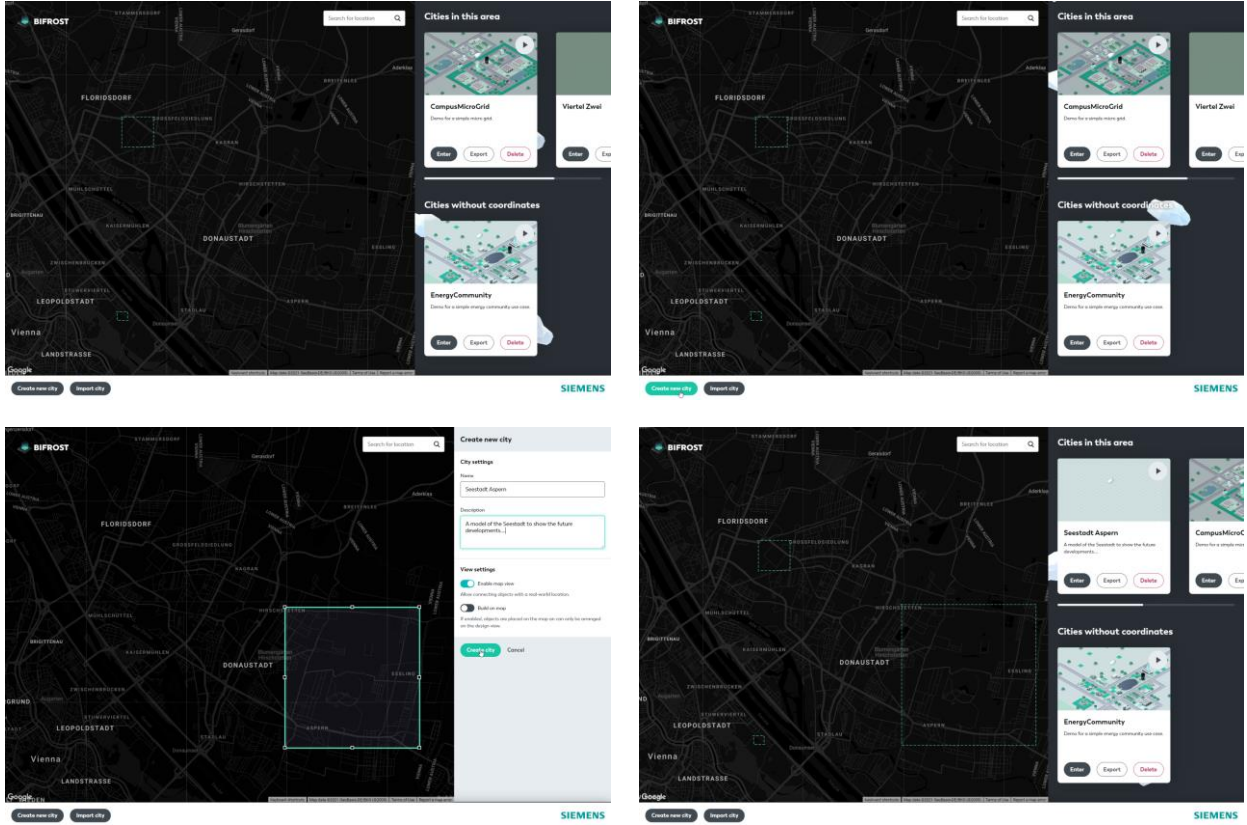

Figure 30: from top left to bottom right: Definition of a new settlement based on entering data via a map

When working within the settlement (representation of the EC) there has to be also a way to allocate certain elements of the schematic view with elements in the real world. The developed technology perspective is shown in Figure 31, the realisation shows Figure 32:

Technology perspective: Geospatial relations 2

Challenge: maintain a consistent user experience across simulation and operation scenarios without sacrificing the BIFROST canvas UI or edging too close to GIS tools.

Proposal 2: Map relation inlay

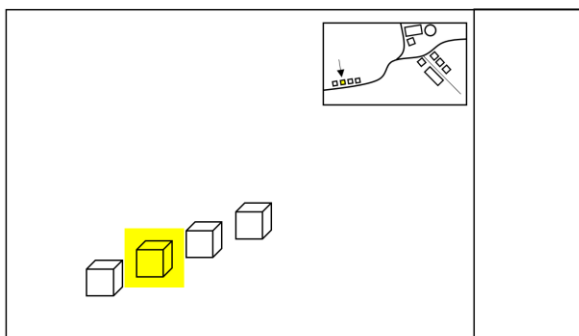

Show a map inlay which highlights the selected object on the BIFROST canvas with the map equivalent. This could be used for engineering purposes as well. There is a danger of creating a disconnect between the actual georelations and the BIFROST projection.

Figure 31: Technology perspective: Geospatial relations within settlement areas

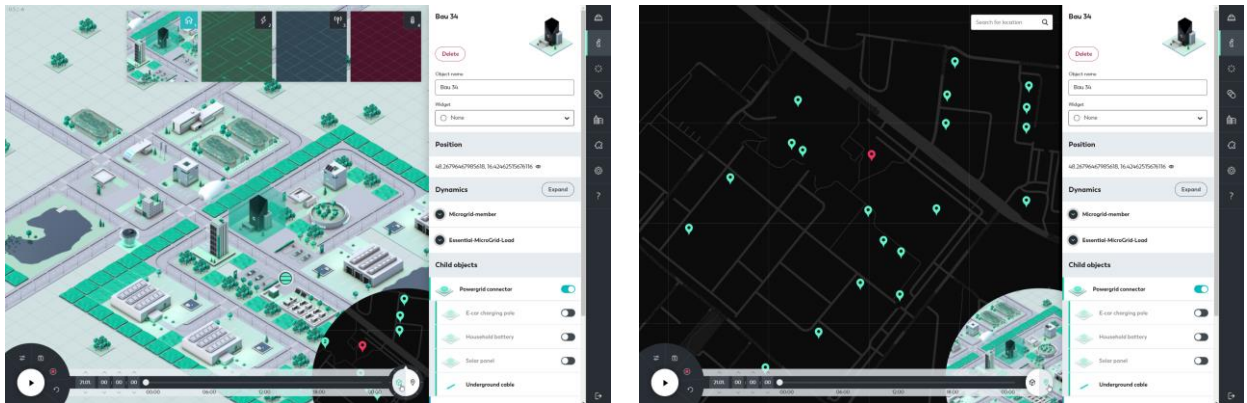

Figure 32: Allocation of elements of the schematic view to elements in the map

Besides this changes also some expansions for possible domains for simulation and modelling of ECs were introduced. Figure 33 gives a summary.

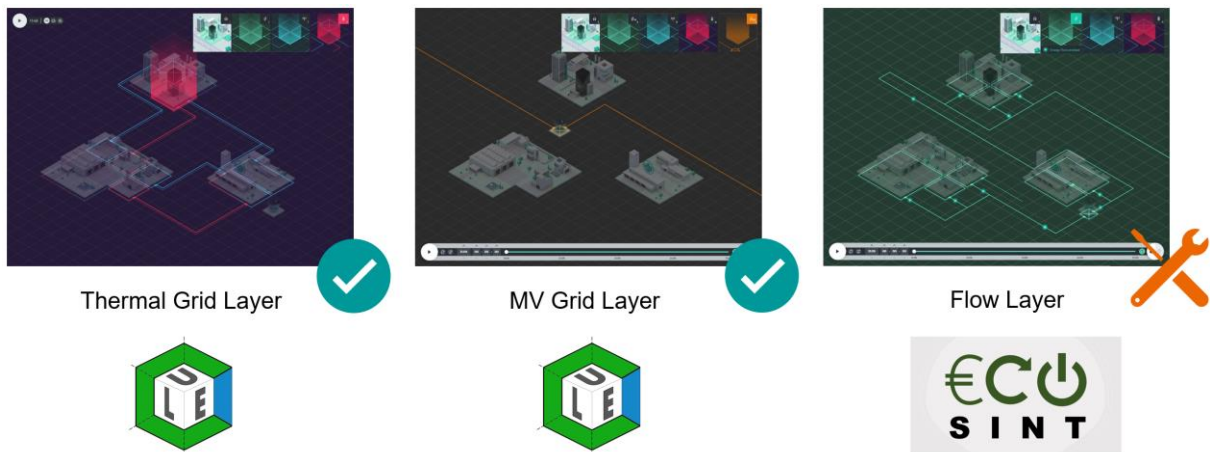

Figure 33: Overview of new domain layers in BIFROST

After CLUE in BIFROST also a thermal grid can be modelled. For ECs also the medium voltage layer can be considered. First ideas for a “flow layer”, to visualize flows within an energy community (like energy between participants or their cash flows) were developed. The implementation was not finished within the CLUE project, but is now done in the follow up project “ECOSINT”.

All these developments were directly derived out of the initial discussions and identified requirements for the LEC Tool Kit. Based on this new BIFROST release SINDRI, the planning tool approach was implemented.

BIFROST – mosaic Coupling”).

A more detailed picture of the single components and data involved gives Figure 22.

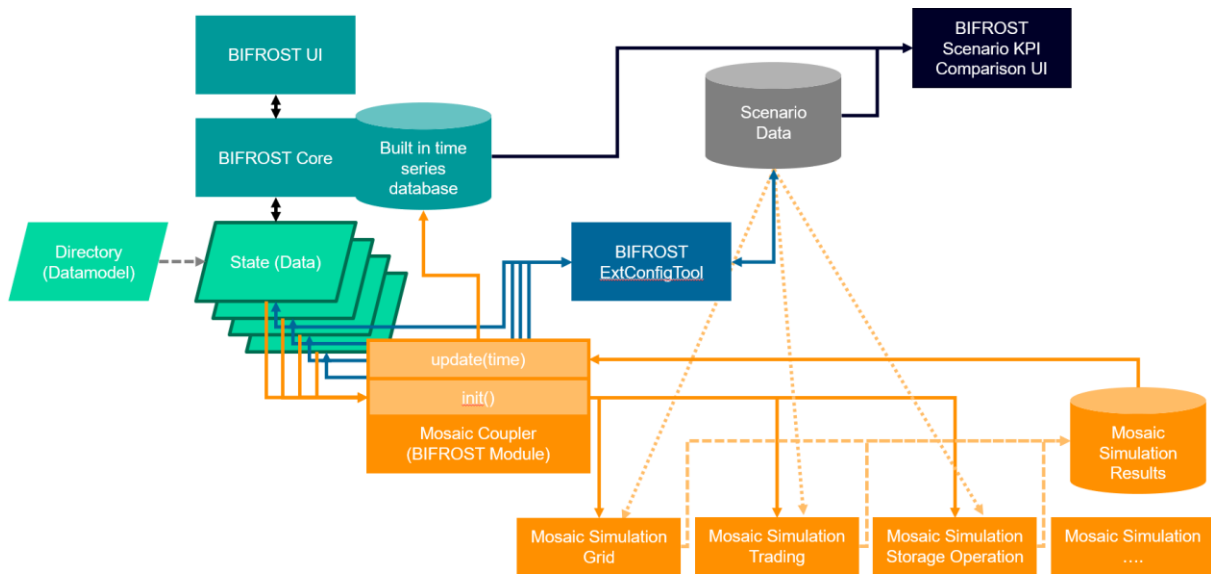

Figure 22: Detailed architecture of the Energy Community Planning Tool

4.6 Simulation Backend

After the configuration of an Energy Community with Bifrost, simulations can be executed by the simulation backend implemented using the Python-based Co-Simulation Tool mosaic (Steinbrink, et al., 2017). This backend is implemented as a REST-server that awaits requests to execute simulations and provides a REST-endpoint that can be used to pull simulation data during the simulation execution to Bifrost. The configuration of the simulation can be set up using current Bifrost system states as inputs, therefore represents the same communities that are configured in Bifrost.

The co-simulation is focused on an electricity grid simulation implemented in pandapower (Thurner, et al., 2018) that is combined with custom asset simulators.

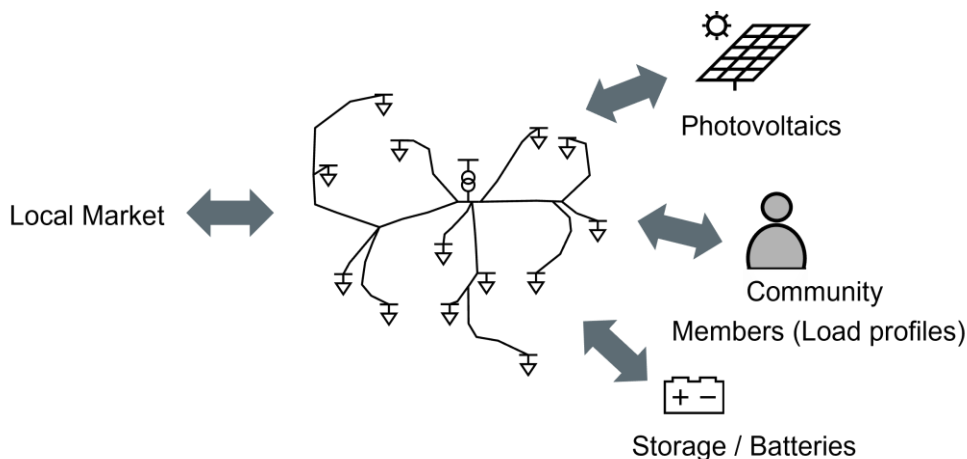

Figure 23: Coupling of the different simulations with the co-simulation approach.

4.6.1 Community Setup

The communities considered within CLUE represent the status-quo of what types of energy communities can be realised in Austria now. These forms of energy communities do not support direct control of assets within a member energy system.

The energy community consists of several different subsystems that are connected through common power and data exchange infrastructure.

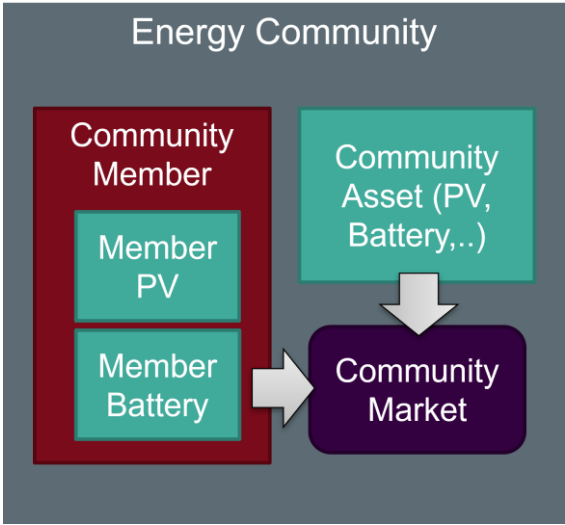

Figure 24: Exemplary energy community with community member energy subsets and information exchange via community market.

An exemplary energy community structure is shown in Figure 24. Each subsystem can include an individual management system, that is responsible for controlling any flexible assets in the subsystem. The goals of the individual management systems do not have to be aligned. If the larger energy community system includes any shared flexible assets, an active management system is needed for their control. Any control behind the meter is subject to member decisions. Certain behaviours can be incentivized through the possibility to sell energy to another participant in the local energy market. Any on the community market transaction is assumed to be equally profitable for both transaction partners.

The community consists of N members. Each of the members has full control his own house energy system, which constitutes as subsystem of the community energy system. Each subsystem can contain L static loads, G static generators and S flexible devices. The residual load of the a sub energy system is then given by Equation 1.

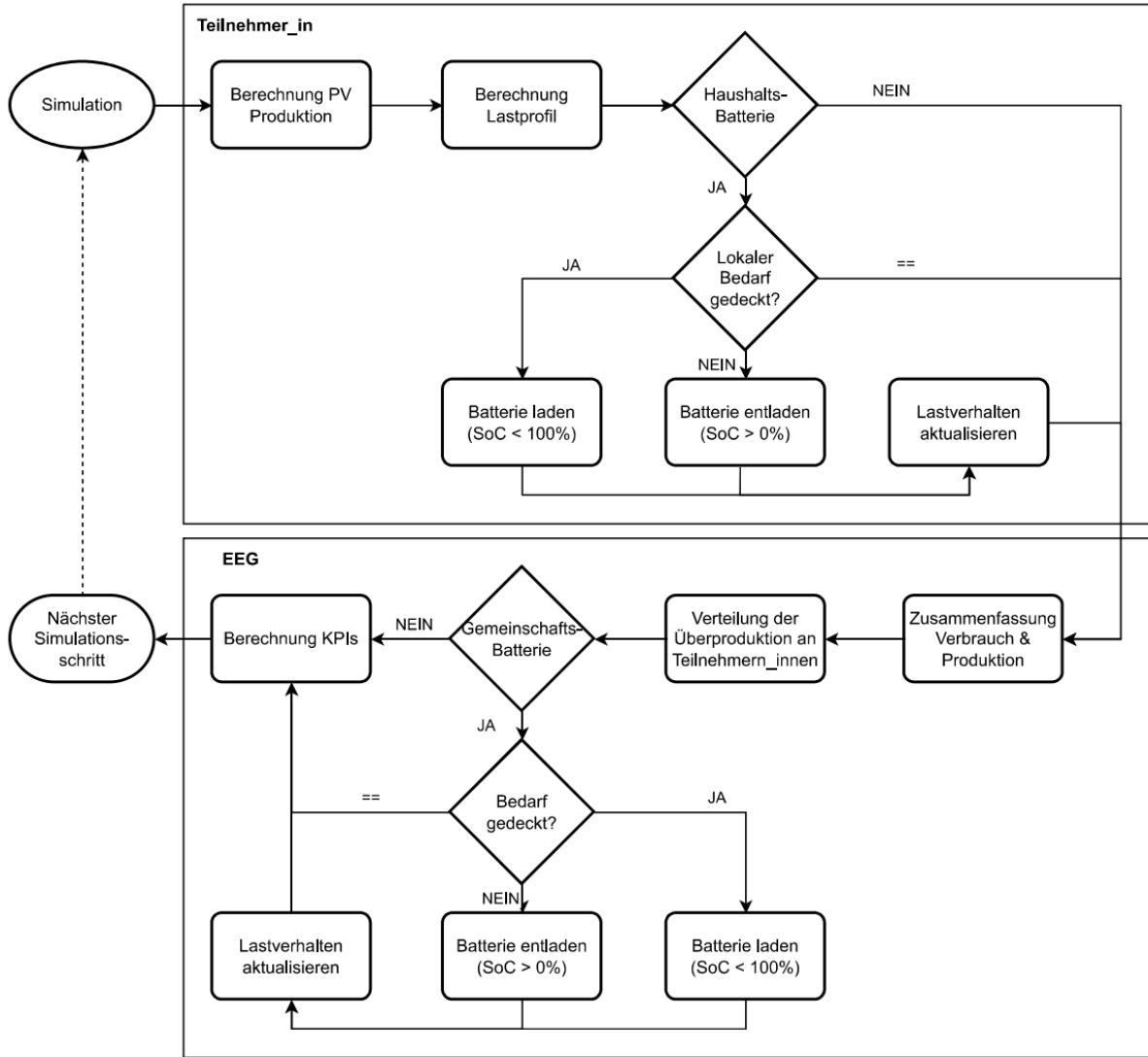

Figure 25: Flowchart of a simulation step of the developed simulation model

Equation 1: Calculation of the residual load of a (sub-) energy system.

$$P_r = \sum_{l=1}^L P_l + \sum_{g=1}^G P_g + \sum_{s=1}^S P_s$$

The residual load P_r is used as input for all the grid connection points that represent subsystems in the power grid simulation. This is done for every timestep and every subsystem of the community.

The community power at any time t is then defined by the sum of P_r of all subsystems within the energy community, as well as any shared assets that might be part of the community.

For N community members, L' shared loads, G' shared generators and S' flexible devices, the residual load of the community is defined by Equation 2.

Equation 2: Calculation of community residual load.

$$P_{r,community} = \sum_{l=1}^{L'} P_l + \sum_{g=1}^{G'} P_g + \sum_{s=1}^{S'} P_s + \sum_{n=1}^N P_{r,n}$$

4.6.2 Asset Modelling

For each type of asset an individual approach for the modelling is followed. The approaches for static profile input modelling as well as storage systems will be described in the following sections.

4.6.2.1 Load profiles

To realize a first proof-of-concept of the simulation environment, standard load profiles are used to reflect load behaviour of the static load of each household in the community.

4.6.2.2 PV profiles

As the most prominent form of energy generation in low voltage grids, PV modules are assumed to be the main contributors to the generation capabilities of the community.

For the modelling of the PV profiles, environmental data is used. The environmental data used is provided by pvgis (Huld, Müller, & Gambardella, 2012).

To receive an active power profile from the irradiation data, the python module pvlib (Holmgren, Hansen, & Mikofski, 2018) is employed. This module offers capabilities of configuring inverter size and type, solar cell material and make as well as positioning and orientation of the PV system to provide an appropriate power profile. AC coupled PV systems are assumed to be the main application of PV eeesystems within local energy communities. DC coupled systems are not considered because they don't behave substantially different from AC coupled systems but require added complexity in the simulation process.

4.6.2.3 Storage Devices

The model for the storage devices is based on a generic storage model developed at the department for Electric Energy Systems at AIT and used throughout several research projects.

To consider losses from all involved components, as well as provide flexibility in the storage medium involved the storage device is strictly separated from the involved inverter.

For this work only AC coupled storage systems are considered. The added complexity of DC coupled systems is assumed not to be relevant for the consideration of the system on a high level.

The battery storage device model separates the model into two distinct sub-models. At first the storage technology is modelled with its physical properties, and in a second step the converter is modelled to couple the storage technology to the AC power system.

For each time step the state of charge is calculated from a given power setpoint.

Equation 3: state of charge (soc) calculation procedure

$$SOC_t = SOC_{t-1} + P_{setpoint} * \eta_{inverter} * \eta_{battery} * \Delta t * \frac{1}{C_{usable}}$$

If the calculated state of charge violates the threshold (either for the maximum charging or discharging capacity of the battery) for the soc the actual power is reduced so that the threshold is not exceeded.

Then the actual power will not be the setpoint but defined by Equation 2. The process of calculating the state of charge of the battery storage system through Equation 3 is repeated to validate the calculated power. Once this has been validated this power is set as the actual power of the simulator for the current time step.

Equation 4: active power determination in case of soc threshold violation

$$P_t = |(SOC_{threshold} - SOC_{t-1})| * \frac{C_{usable}}{\Delta t * \eta_{inverter} * \eta_{battery}}$$

As the power that is actually regulated is the power at the AC connection point, the factor of $\eta_{inverter}$ should not be forgotten. This factor is determined from a table of actual measurements of inverter performance under different loading percentages. For low loading conditions, very low efficiencies can be observed on the inverter side.

4.6.3 Flexible asset control

As a simple approach to mimic currently often implemented self-consumption maximisation control a very simple algorithm was devised.

The inputs of the algorithm are the currently measured load and generation in the (sub) system for which the control is implemented.

Assuming there are S flexible components, the algorithm first determines the sum of the setpoints for all available flexible components. This total setpoint is determined from the currently available inflexible load and generation. The total setpoint is calculated as shown in Equation 5.

Equation 5: Setpoint determination logic for flexible assets.

$$P_{t,setpoint,total} = \sum_{l=1}^L P_{t,l} + \sum_{g=1}^G P_{t,g}$$

Equation 6: assignment of setpoints in case of multiple dynamic assets.

$$P_{t,setpoint,component} = P_{t,setpoint,total} * \frac{1}{S}$$

The $P_{t,setpoint,total}$ is distributed evenly among all S involved flexible components as shown in equation Equation 6.

If one of the components cannot support the portion of the setpoint that it would be assigned through this equal distribution among flexible assets, the algorithm determines what is possible to the component and distributes the rest equally among the other flexible components.

For instance, if a battery has a state of charge that is close to its threshold, but the setpoint power would exceed the threshold state of charge on the battery, the appropriate charging power for the component is determined through Equation 4.

This means that the control algorithm is aware of the status of all involved flexible component, and conducts validates operation of components is possible before distributing setpoints.

If S'' of the flexible components cannot support the current setpoint, the setpoints for the other $S-S''$ components is determined through Equation 7.

Equation 7: Determination of set-point in case of physical constraints.

$$P_{t,setpoint,component} = (P_{t,setpoint,total} - \sum_{s=1}^{S''} P_{t,setpoint,s}) * \frac{1}{S - S''}$$

4.6.4 Community Market simulation

As a starting point for the implementation of community markets, the current legislation in Austria regarding implementation of energy communities on a local level is assumed. Energy prices cannot vary dynamically, but can only be assigned statically through a contract between community and member.

The community market is not fully dynamic, but rather distributing available power from community members and shared assets according to community members actual power needs.

The community price that is used to sell energy within the community is set at the midway point between the energy provider price for energy and the feed in tariff compensation awarded to generation owners. Both price levels are assumed to be the same for all participants.

The implemented market offers the possibility for every member to bid load and generation at a double-sided auction. If a member does not want to buy or sell energy, they are issuing a buy bid without any required energy. After the bidding process resulting transactions are calculated through a market clearance function for all issued bids. In the first implementation step every community member bids at the same price, the community price, and the clearance function leads to an equal distribution of the required energy among the auction participants.

Assuming π auction participants, each participant can act as a buyer or a seller in the current market time frame. The amount of buyers β plus the amount of sellers σ is then equal to π .

Each sellers σ' issued energy bid is then defined by the energy they want to sell $E_{\sigma'}^{bid,sell}$, the price they want to sell the energy for $p_{\sigma'}^{bid,sell}$ and the agent name η .

For the buyers β' the bids are also defined by the amount of energy they want to buy $E_{\beta'}^{bid,buy}$, the price they want to buy the energy for $p_{\beta'}^{bid,buy}$ and the agent name η .

If for the bids that were issued to the auction the balance of bid energies is described by the inequality Equation 8, ie. more bids have been issued to the auction to buy energy than bids to sell energy, the amount of energy that is exchanged between a pair of buyer β' and seller σ' is determined through equation Equation 9.

Equation 8: energy buying/selling bid inequality 1

$$\sum_{b=1}^{\beta} E_b^{bid,buy} > \sum_{s=1}^{\sigma} E_s^{bid,sell}$$

Equation 9: trade amount determination for higher amount of buying bids issued to the auction

$$E_{\beta',\sigma'}^{trade} = E_{\sigma'}^{bid,sell} * \frac{E_{\beta'}^{bid,buy}}{\sum_{b=1}^{\beta} E_b^{bid,buy}}$$

If more bids have been issued to the market to sell energy than to buy energy for the current market time frame (if inequality Equation 10 holds for the issued bids) the market clearing is done through equation Equation 11.

Equation 10: energy buying/selling bid inequality 2

$$\sum_{s=1}^{\sigma} E_s^{bid,sell} \geq \sum_{b=1}^{\beta} E_b^{bid,buy}$$

Equation 11: trade amount determination for higher amount of selling bids issued to the auction

$$E_{\beta',\sigma'}^{trade} = E_{\beta'}^{bid,buy} * \frac{E_{\sigma'}^{bid,sell}}{\sum_{s=1}^{\sigma} E_s^{bid,sell}}$$

These clearing procedures ensure that there is a fair distribution of available energy among everybody wants to acquire energy on the local market. It is also ensured that every participant can sell a fair amount of their generation they want to sell on the local market, even if there is not enough demand to be able to sell the whole amount of energy.

Transaction prices are not determined dynamically, as the prices are assumed to be contractually fixed amongst all participants in the community. Therefore, there is no consideration of prices in the clearing process.

Including dynamic prices for an auction would need some form of intelligence at the user side, that is able to determine what prices to bid at a certain time of the day or in a certain system state to achieve an optimal result from the auction clearing process.

4.6.5 Simulation Execution

To combine all the before mentioned modelling approaches the modelled components and management entities are all simulated in a discrete-time co-simulation.

All simulated systems are assumed to be quasi-static at the evaluated time scales, meaning that changes in systems do not occur in frequencies orders of magnitude higher than the simulation time step Δt_{sim} . This simulation time step was chosen to be 15

minutes in the first implementation. This time step was selected due to it being the same frequency at which data was available for static data-based simulators.

Co-simulations are set up using the mosaik framework (Steinbrink, et al., 2017) and each involved component is simulated individually, and for each time step data exchanges are realized where necessary to facilitate necessary functions.

4.7 BIFROST – Adoptions for LEC Tool Kit Application

Out of the requirements for the EC Planning Tool some adoptions of BIFROST derived, which were introduced in the release version “SINDRI”. In the following some of these changes are summarized.

One of the biggest changes was the development of a complete new simulation engine and introduction of a Data Core.

Technology perspective: The new Common Simulation Core (simulation example)

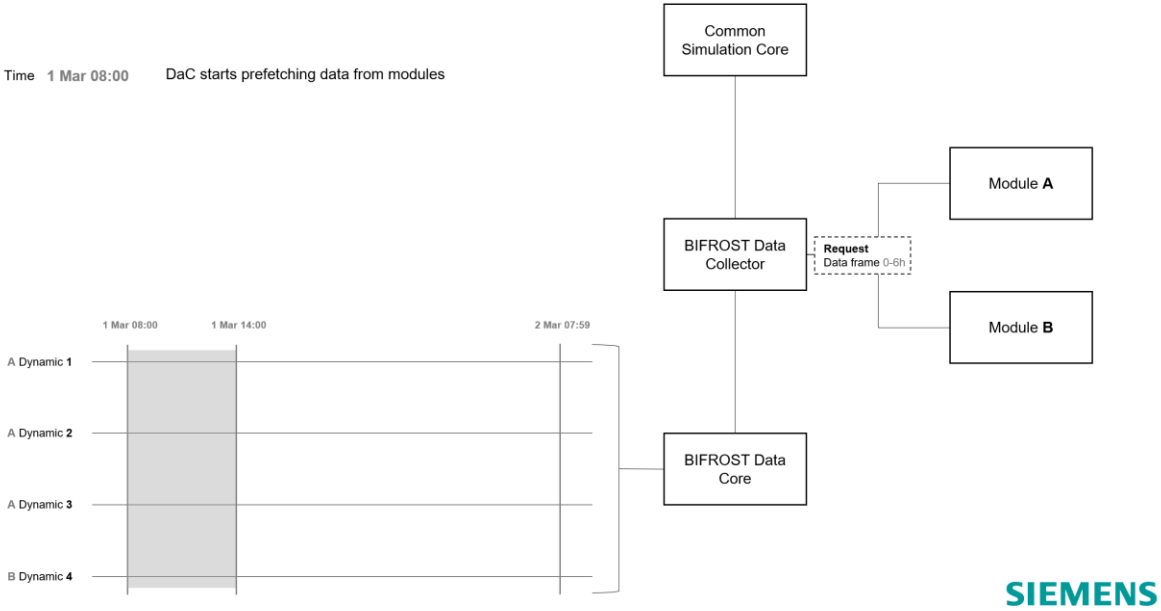

Figure 26: Technology perspective: Prefetch of simulation data

BIFROST should be enhanced to work with complete time series instead of single time simulations. The simulation data is provided by the modules in a fast way and is stored within BIFROST in a separate data base, see Figure 26.

To replay this data in the UI, single data points are later fetched from the data base and used, to show system states, see Figure 27

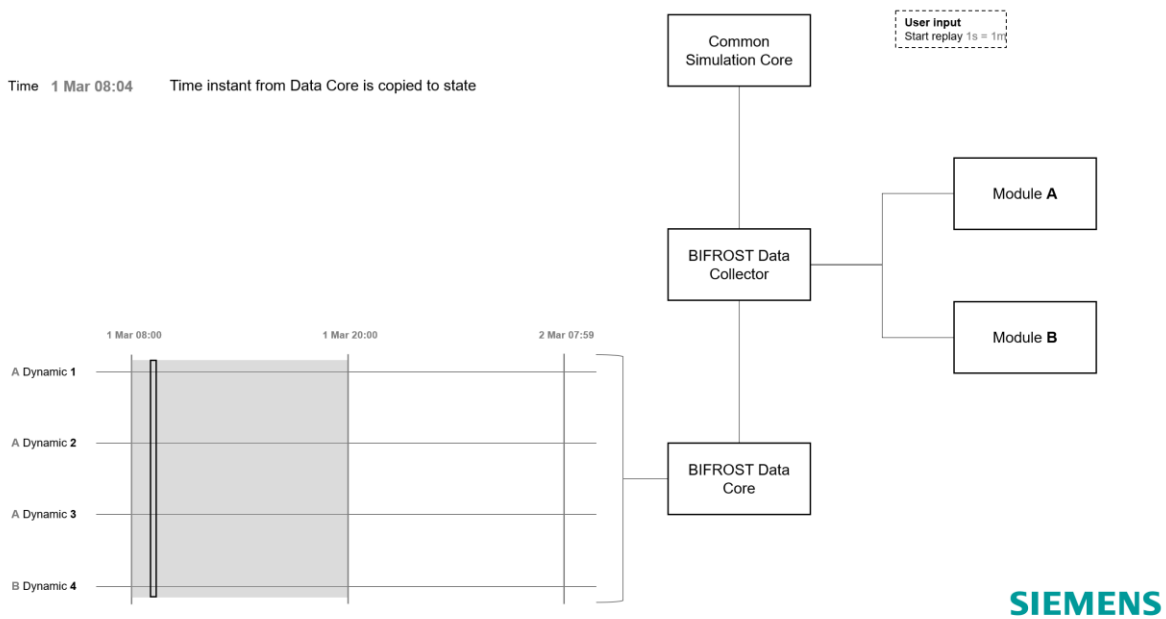

Figure 27: Technology perspective: Replay of data based on already made simulations

This technology perspective was implemented and realized in an adapted BIFROST UI, see Figure 28

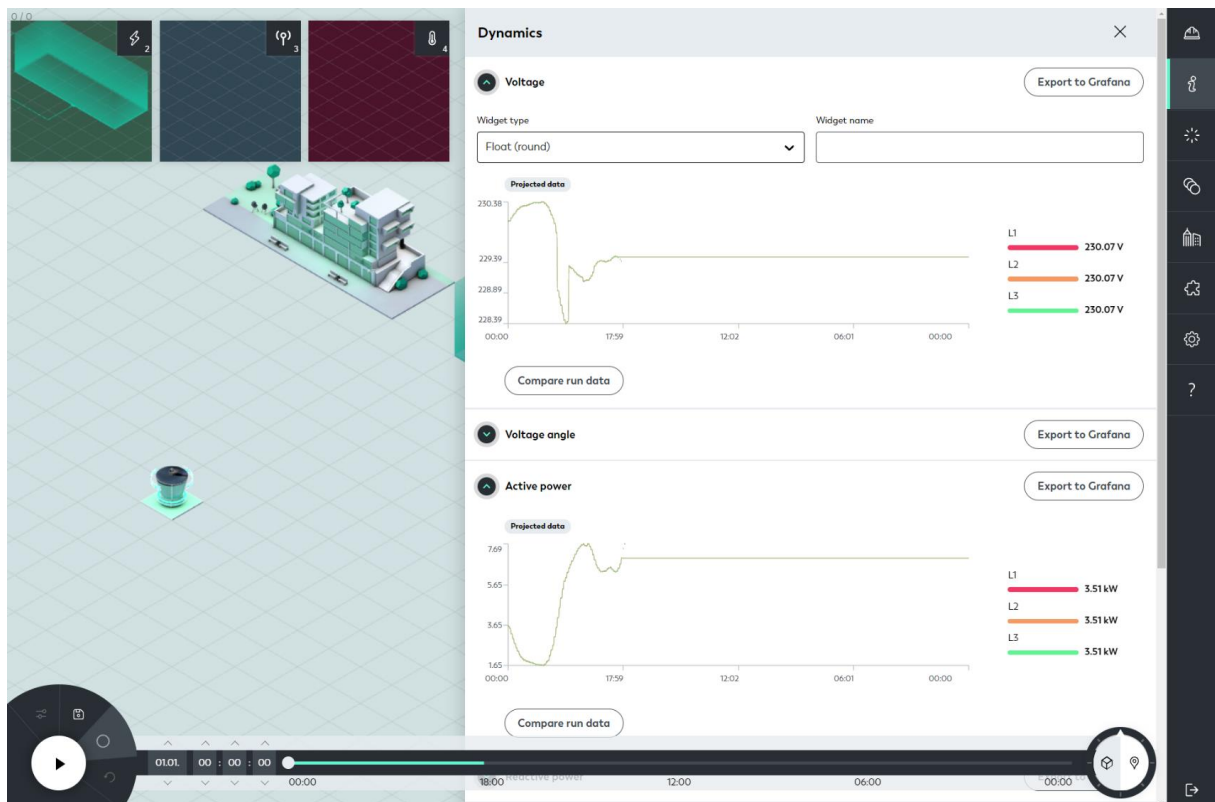

Figure 28: Realisation of the technology perspective of prefetching and replaying of simulation data

The potential operation mode (see section "4.1.1.2 Operation Phase"), despite not planned to be realized in CLUE, rose the question for a more convenient way to allocate real world data points and object to schematic elements of the BIFROST UI.

The corresponding technology perspective is shown in Figure 29.

Technology perspective: Geospatial relations 1

Challenge: maintain a consistent user experience across simulation and operation scenarios without sacrificing the BIFROST canvas UI or edging too close to GIS tools.

Proposal 1: Scenario selection and map layer

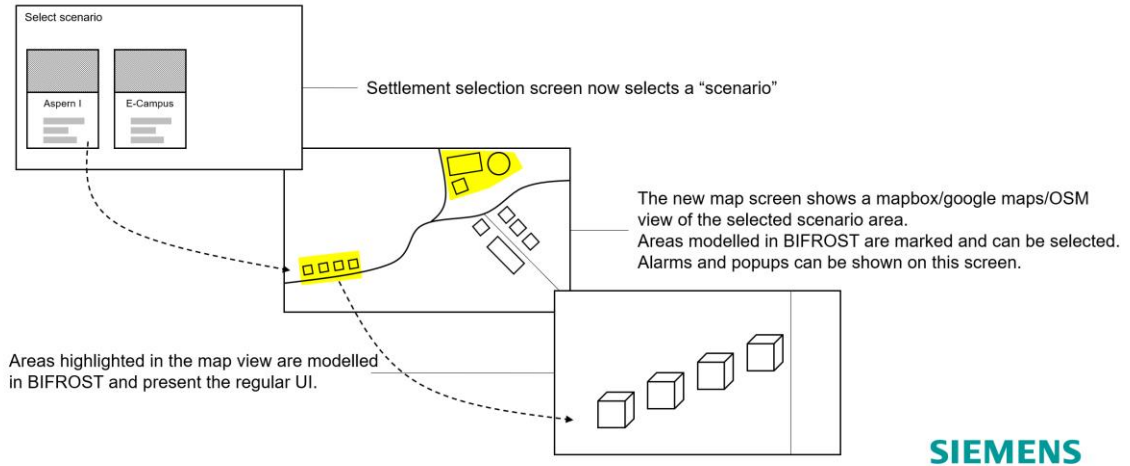

Figure 29: Technology perspective: Geospatial relations of whole settlement areas

The proposed solution over using a map to define an area of interest was than implemented, see Figure 30:

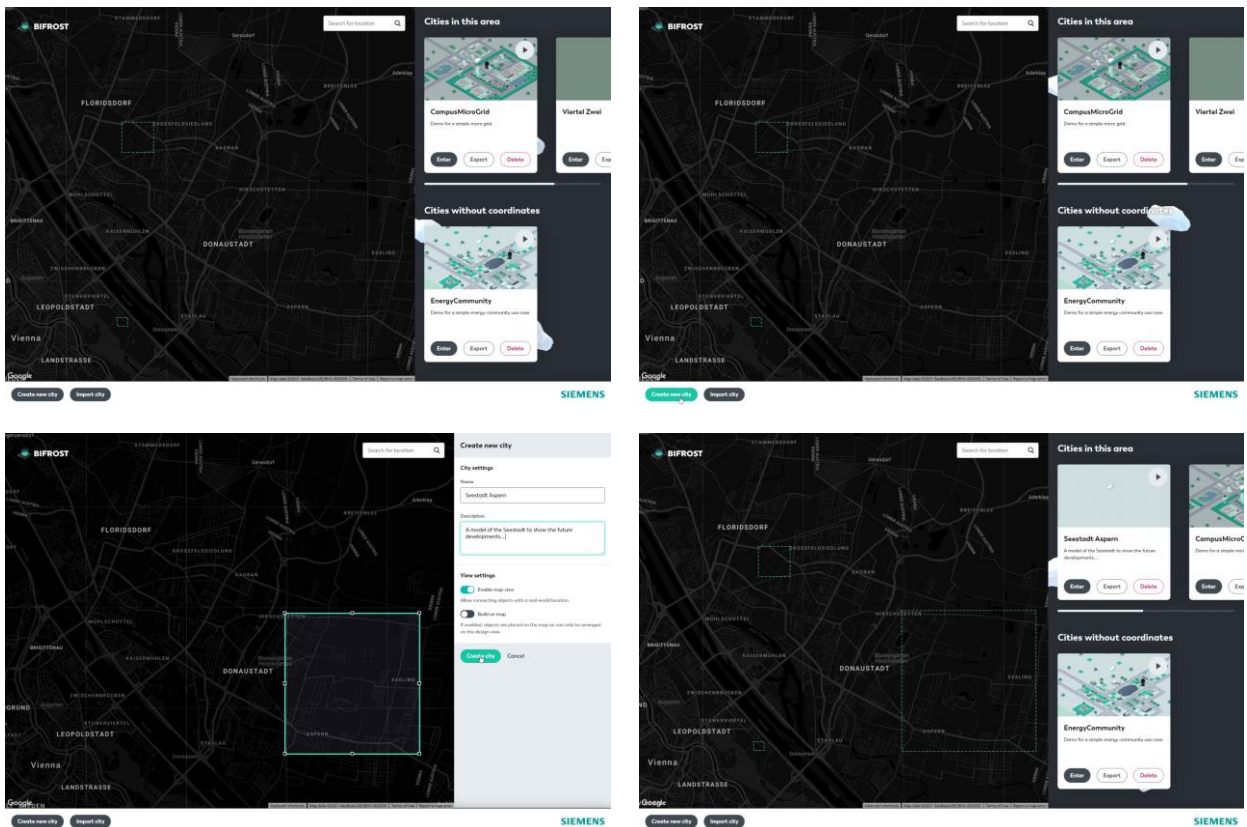

Figure 30: from top left to bottom right: Definition of a new settlement based on entering data via a map

When working within the settlement (representation of the EC) there has to be also a way to allocate certain elements of the schematic view with elements in the real world. The developed technology perspective is shown in Figure 31, the realisation shows Figure 32:

Technology perspective: Geospatial relations 2

Challenge: maintain a consistent user experience across simulation and operation scenarios without sacrificing the BIFROST canvas UI or edging too close to GIS tools.

Proposal 2: Map relation inlay

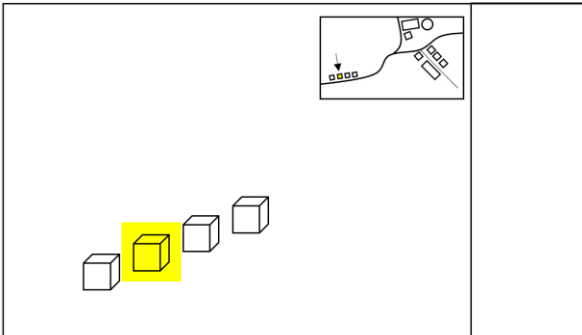

Show a map inlay which highlights the selected object on the BIFROST canvas with the map equivalent. This could be used for engineering purposes as well. There is a danger of creating a disconnect between the actual georelations and the BIFROST projection.



Figure 31: Technology perspective: Geospatial relations within settlement areas

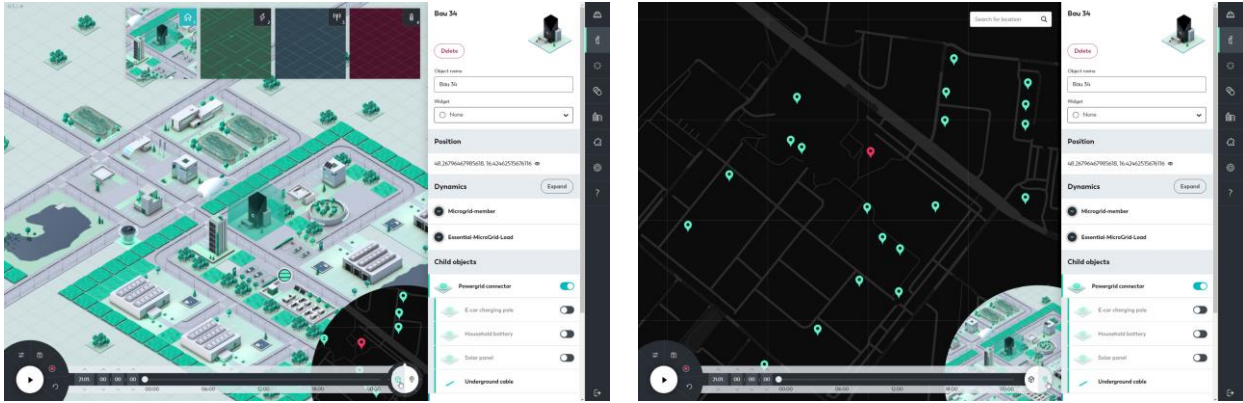

Figure 32: Allocation of elements of the schematic view to elements in the map

Besides this changes also some expansions for possible domains for simulation and modelling of ECs were introduced. Figure 33 gives a summary.

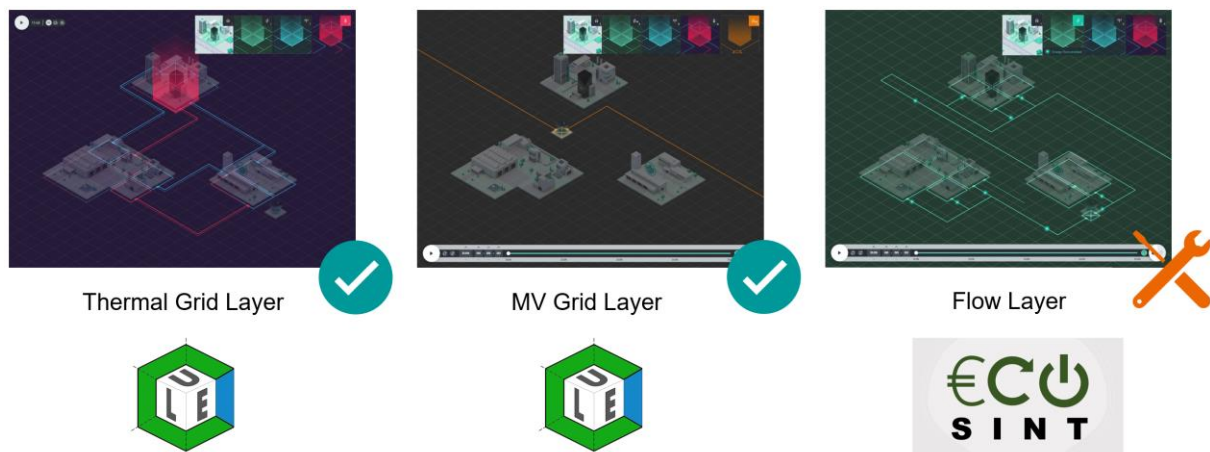

Figure 33: Overview of new domain layers in BIFROST

After CLUE in BIFROST also a thermal grid can be modelled. For ECs also the medium voltage layer can be considered. First ideas for a “flow layer”, to visualize flows within an energy community (like energy between participants or their cash flows) were developed. The implementation was not finished within the CLUE project, but is now done in the follow up project “ECOSINT”.

All these developments were directly derived out of the initial discussions and identified requirements for the LEC Tool Kit. Based on this new BIFROST release SINDRI, the planning tool approach was implemented.

4.8 BIFROST – mosaic Coupling

The CLUE mosaik Coupler is Bifrost-module which is the interface between BIFROST and the mosaik-simulation tool.

On the init call, a connection check to the mosaik-influx database is run and the parameters of the current BIFROST simulation run (date, start, end, dynamic configuration) are sent via REST to the mosaik-simulation. After that, the mosaik-simulation is started and runs asynchronously in the background.

While the module is in its update-cycle it requests the current simulation-progress. If the progress is sufficient, it requests a data-block from the mosaik-influx database. This data is parsed and written to BIFROST as fast as possible. This continues until the BIFROST simulation run is finished. If no data is received for 10 tries, the mosaik-simulation is stopped, and the module expects a new run to work properly again.

4.9 External Config Tool

After completion of the design phase in the BIFROST UI, the configuration phase follows. In this phase, different scenarios are configured for the created ECs with the help of an external configuration tool. A scenario consists of a set of heterogeneous parameters that influence the behavior of the EC. In the current development stage, parameters concerning the load behavior of the individual participants and the configuration of PV systems and storage are implemented. A configuration of the charging infrastructure for electric vehicles is planned for future development stages.

The load profiles are defined either via standardized load profiles that are scaled to a specific annual consumption or via user-defined load profiles that can be uploaded and used via a corresponding interface. The load profiles can be scaled via an optional scaling factor. The following parameters can be configured for a PV system:

- Orientation of the modules,
- tilt angle of the modules,
- installed power of PV modules,
- efficiency of the PV modules,
- power of the inverter used and
- efficiency of the inverter.

The same parameters shall be set for prosumers and shared generation. Storage is defined by

- a maximum capacity,
- a charge level at the beginning of the simulation and the
- maximum charge and
- maximum discharge power.

The capacity is assumed to be the usable capacity. Both community batteries and storage units in buildings can be created and configured. Default values are basically stored for all these parameters, which reduces the configuration effort. After the configuration of the individual buildings has been completed, the simulation period must still be defined for the simulation via start and end dates. The simulation can be started directly via the interface of the external configuration tool. It is also possible to start several simulations of different scenarios, which are then processed sequentially.

After completion of the simulation, the corresponding results can be analyzed in the evaluation phase. On the one hand, the BIFROST interface can be used to inspect detailed evaluations. On the other hand, the interface of the external configuration tool allows defined key figures from different scenarios to be compared. Currently, three key figures are available, but it is planned to integrate further key figures that were identified in the course of this work.

Self-sufficiency represents the degree of self-sufficiency within the EEG. The energy costs incurred are calculated. Only consumption-dependent metrics are taken into account. By evaluating the resulting CO₂ emissions of the scenario, the sustainability of the EEG concept can be concluded. The metrics of the different scenarios are compared in a table. The best and worst values are highlighted in color.

The external configuration tool consists of a user interface that was implemented as a single-page web application, as well as a web server and a relational database to persist the created scenarios. React¹ was used as the framework for implementing the user interface. The web server was developed in Node.js² as a runtime environment and

¹ <https://reactjs.org/>

² <https://nodejs.org/en/>

Fastify³ was used as the web framework. The relational database was implemented with SQLite⁴. Some excerpts of the user interface are shown in the Figure 34.

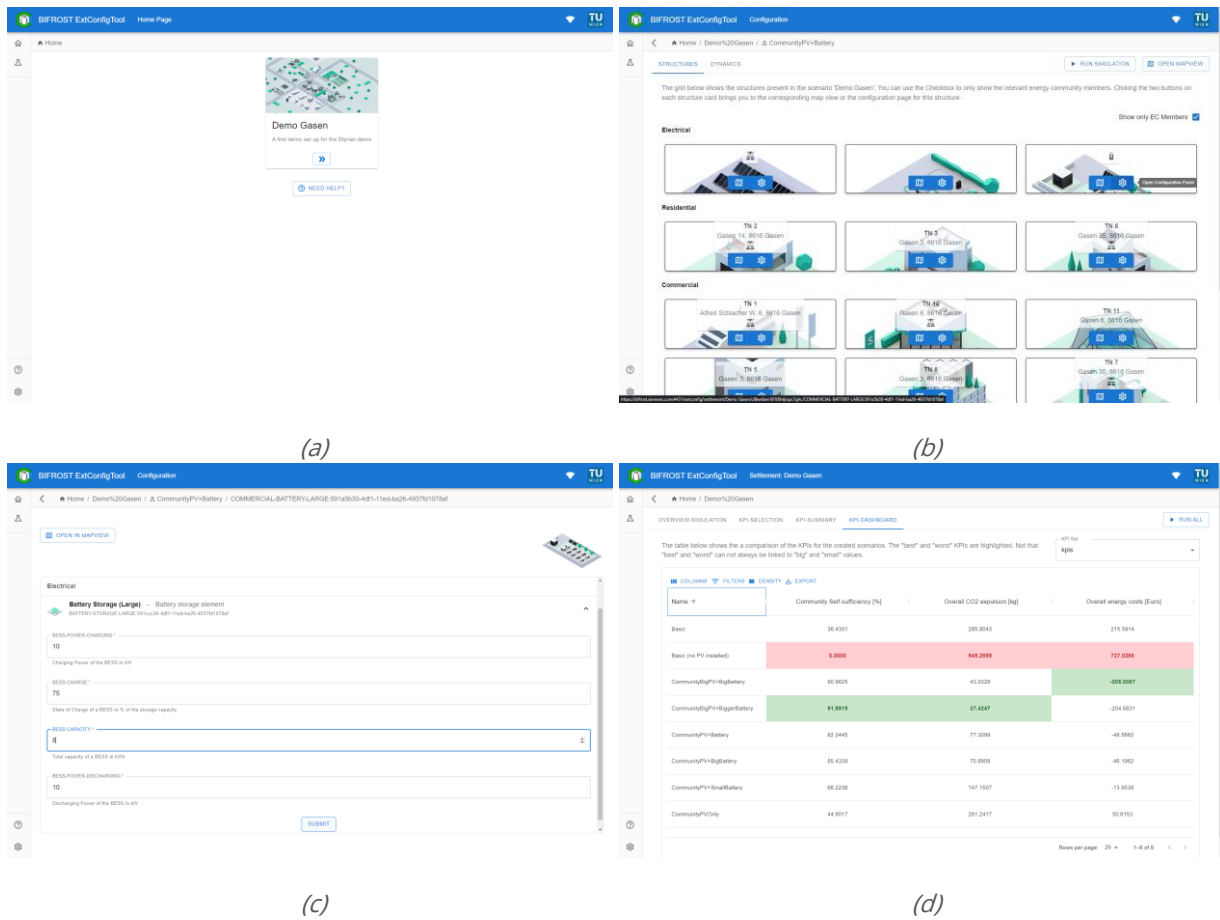

Figure 34: Screenshots of the External Config Tool

On the start page, the available settlements are displayed, see Figure 34 (a). Here, a settlement is selected for which the scenarios can subsequently be created. Figure 34 (b) shows the overview of the buildings and installations available in the EEG. Buildings that are equipped with special facilities such as PV, battery or charging infrastructure are highlighted with an icon. Self-sufficiency represents the degree of self-sufficiency within the EC. The energy costs incurred are calculated. Only consumption-dependent metrics are taken into account. By evaluating the resulting CO2 emissions of the scenario, the sustainability of the EC concept can be concluded. The metrics of the different scenarios are compared in a table. The best and worst values are highlighted in color. Figure 34 (c) shows the configuration view of a community battery. The defining parameters can be set here. Figure 34 (d) shows the summary evaluation table of the key figures from different scenarios. The best and worst values are highlighted in color for easier reading.

During the development of the external configuration tool, particular emphasis was placed on the easy adaptability of the interface to new use cases. The parameters and key figures to be configured, which can be compared with each other after completion of the simulation, are defined via a configuration file. The desired configuration can be defined

³ <https://www.fastify.io/>

⁴ <https://sqlite.org/index.html>

by environment variables when the software is started. This means that this tool can also be adapted to other use cases with simple modifications. Thus it was also possible to extend the represented architecture from Figure 22 by the external configuration tool.

4.10 Results

4.10.1 Example for a Planning Workflow

With the provided data from the EC in Gasen it was possible to implement a demo case for a planning workflow. This is shown in the following screenshots to illustrate the realization of the user story defined in the beginning of the project (see section “4.1.2 User Story for an Energy Community Planning Tool”)

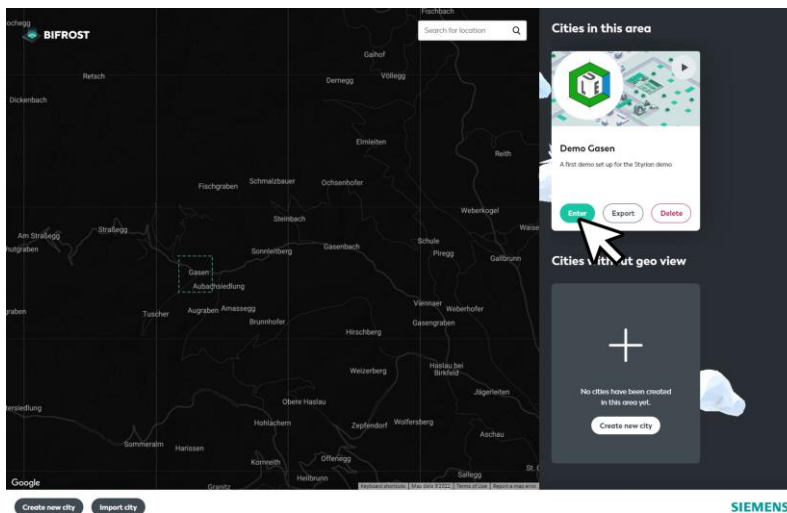

Figure 35: Entering the demo settlement of Gasen, Styria

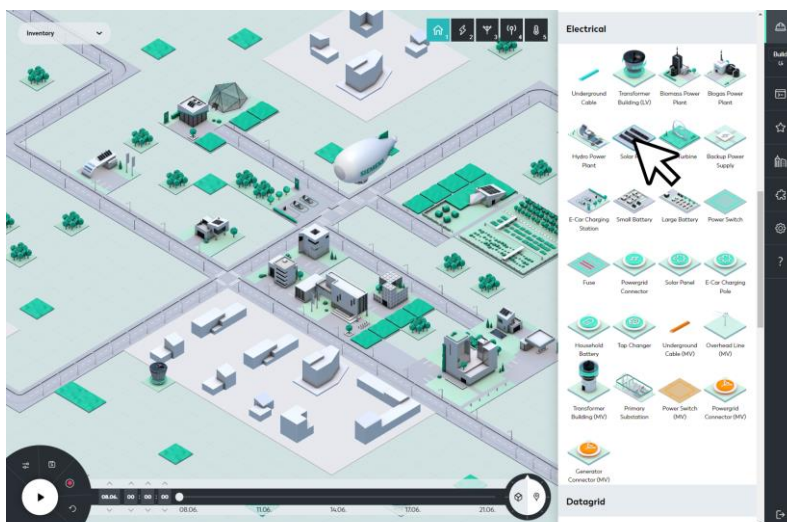

Figure 36: The community should be expanded by a central PV system...

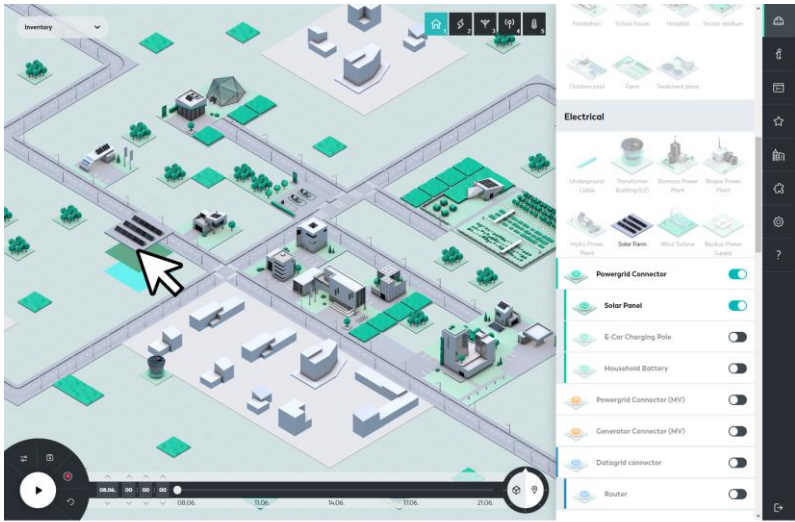

Figure 37.. which is placed into a near free area, ...

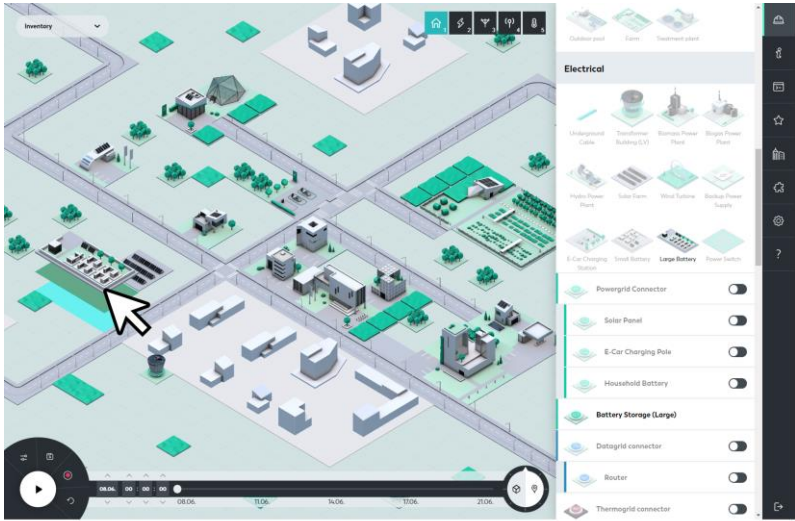

Figure 38: and a community storage system.

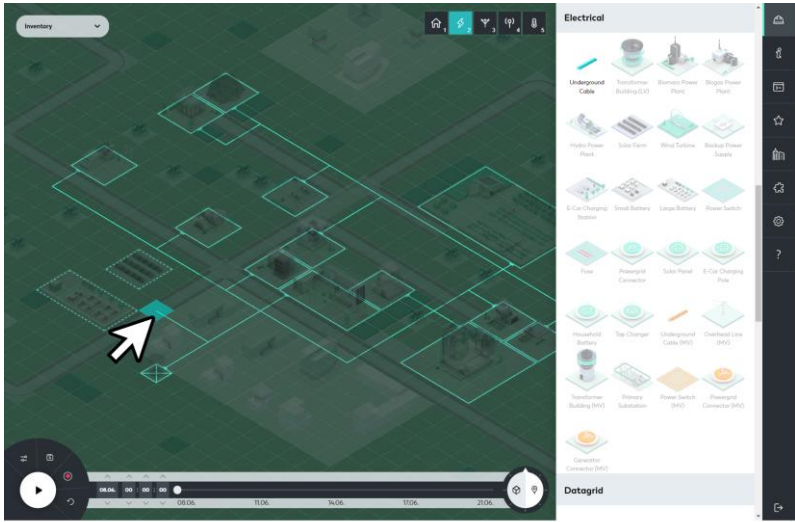

Figure 39: The new components are connected to the existing electrical grid.

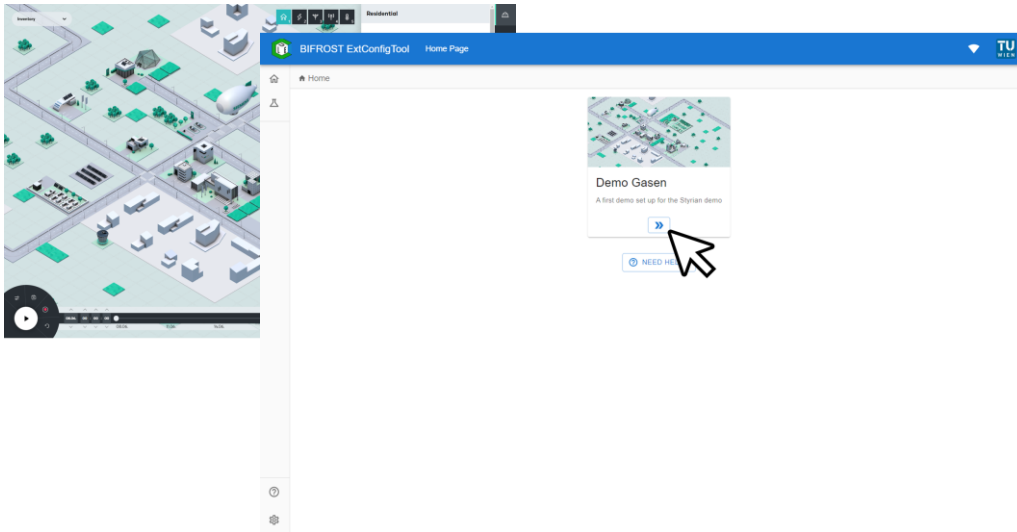

Figure 40: After this the External Config Tool is used to configure the interesting scenarios.

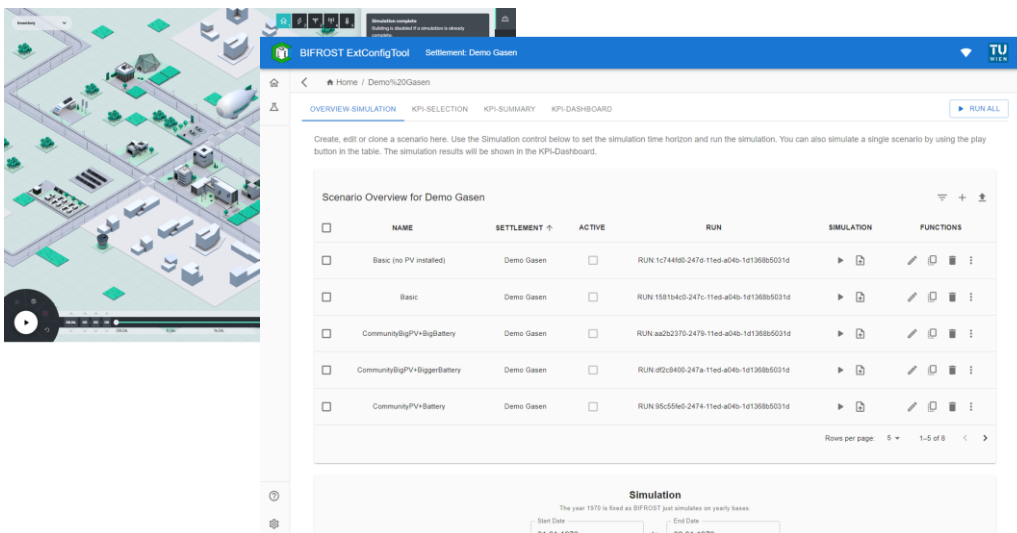

Figure 41: For each of the scenarios a new set of options can be defined (or copied and then altered)

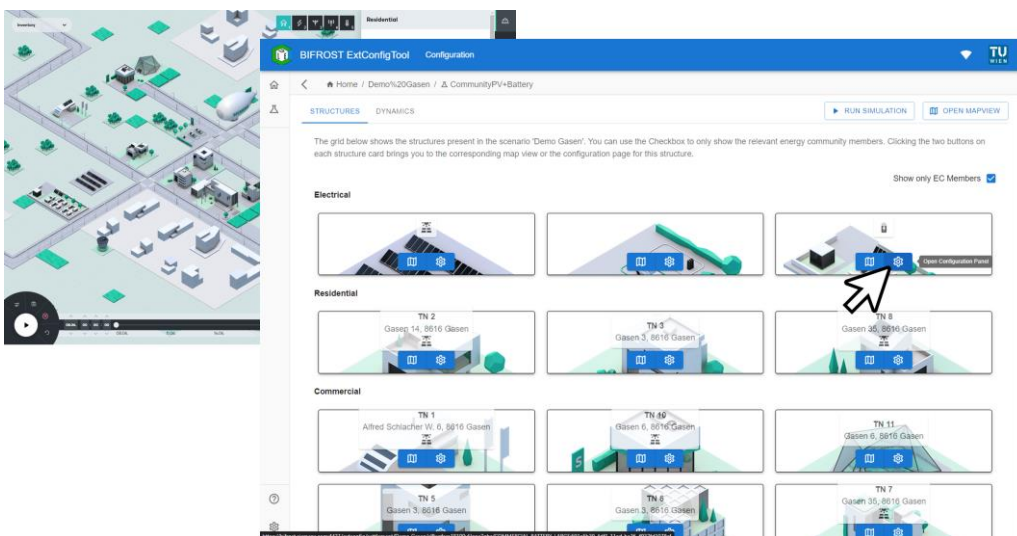

Figure 42: In the tool all components can be configured, like here...

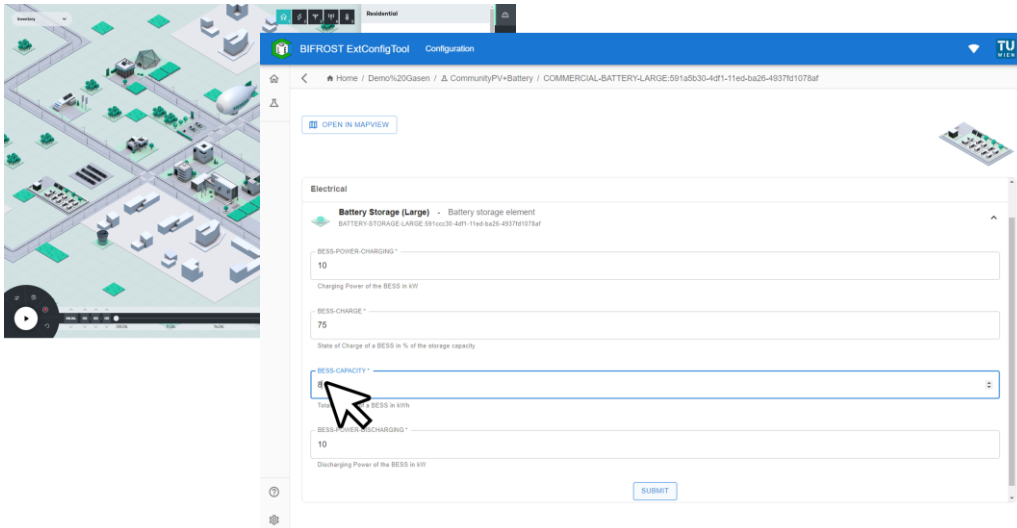

Figure 43: ... the capacity of the storage system.

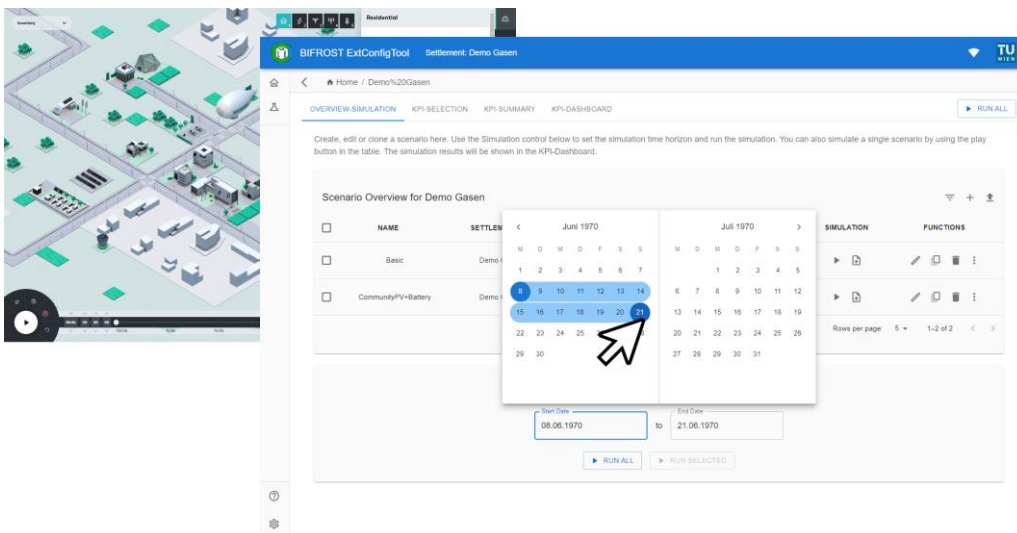

Figure 44: After defining a simulation period...

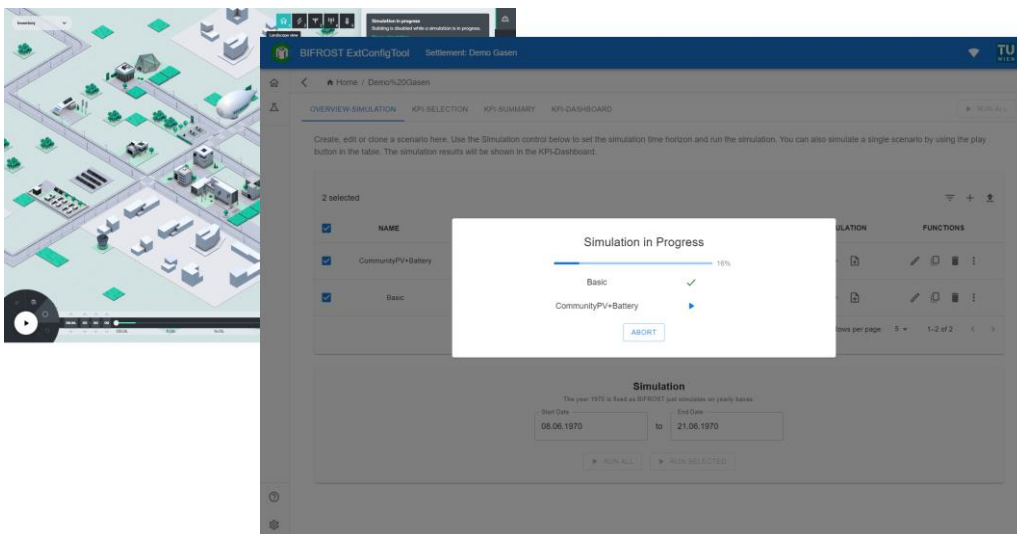

Figure 45: the EC Simulation Backend and BIFROST perform all needed calculations and collect the data.

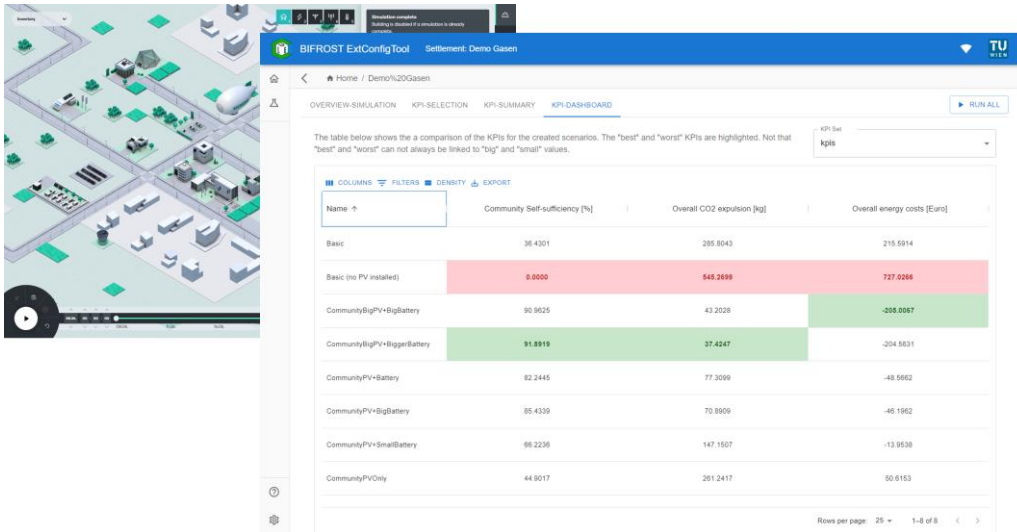

Figure 46: After all simulations are finished the External Config Tool shows a summary in form of a table. Depending on the different KPIs, the best solution for the community in Gasen can be selected.

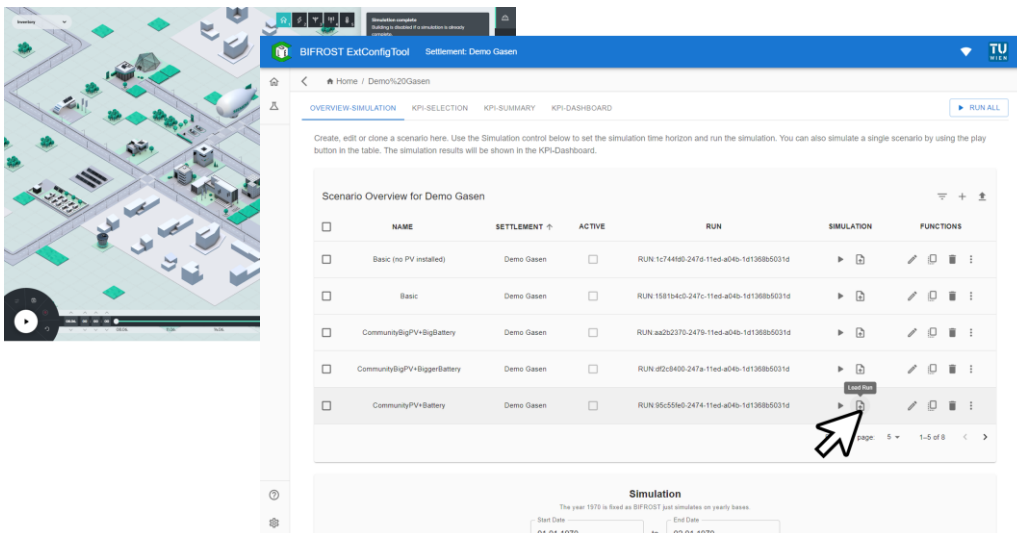

Figure 47: To investigate certain simulation results, these can easily be activated in the BIFROST UI...

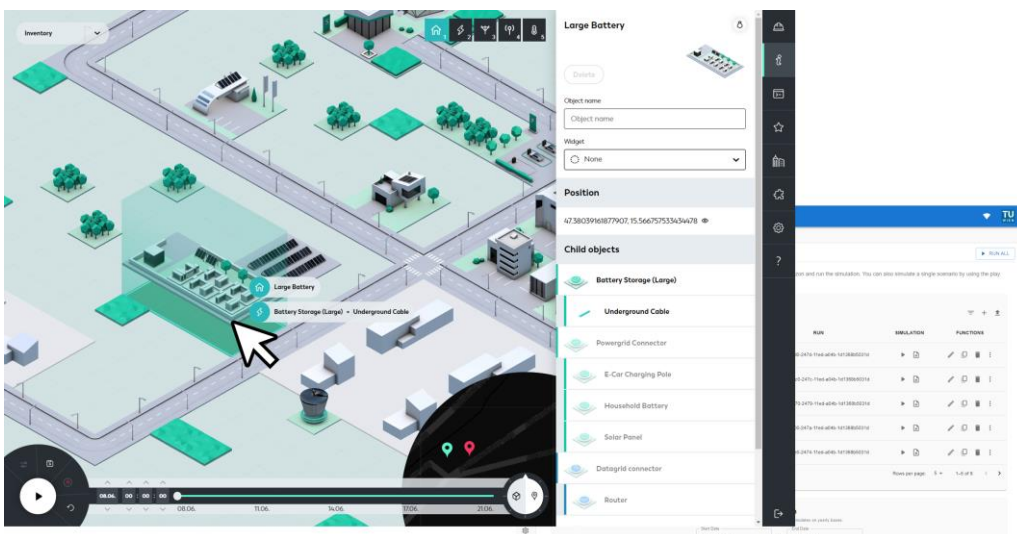

Figure 48... and there visualized, like here at the storage system...

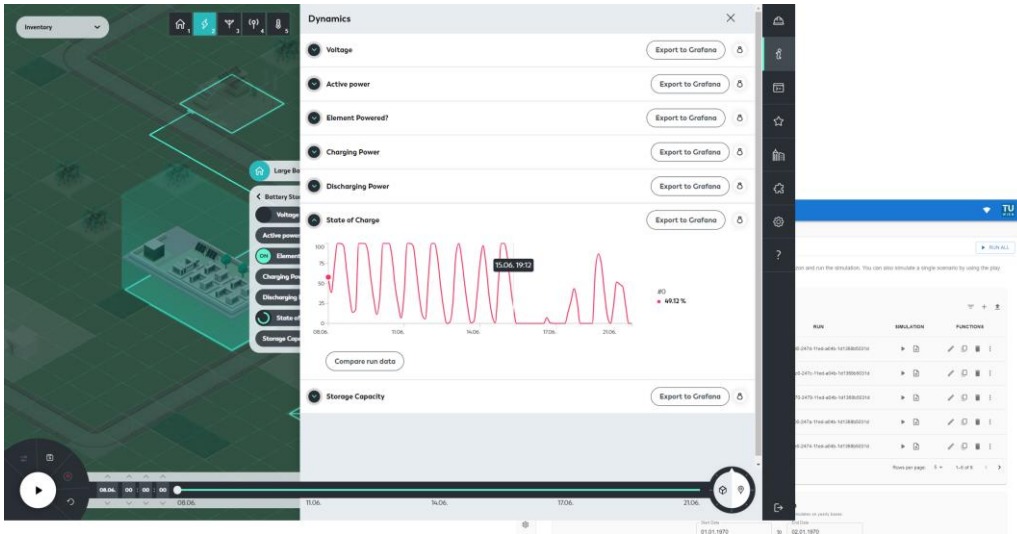

Figure 49: ... the development of the state of charge over the simulation period.

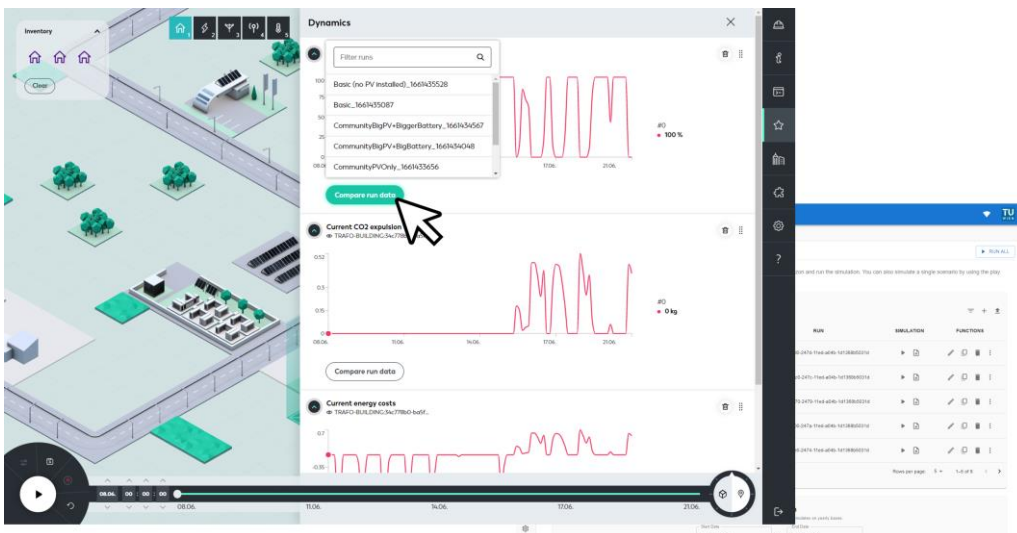

Figure 50: Also a comparison is possible in the BIFROST UI, here the KPI Community Self Sufficiency is compared..



Figure 51... between two scenarios, which are distinguished by the capacity of the storage system.

4.10.2 Workshop with Project Partners

During a Workshop at the CLUE general meeting in Malmö, Sweden, all project partners got access to the Energy Community Planning Tool and could try it out. The participants were asked afterwards about their experiences and opinions while working with the developed tools. Following some of the results out of this survey:

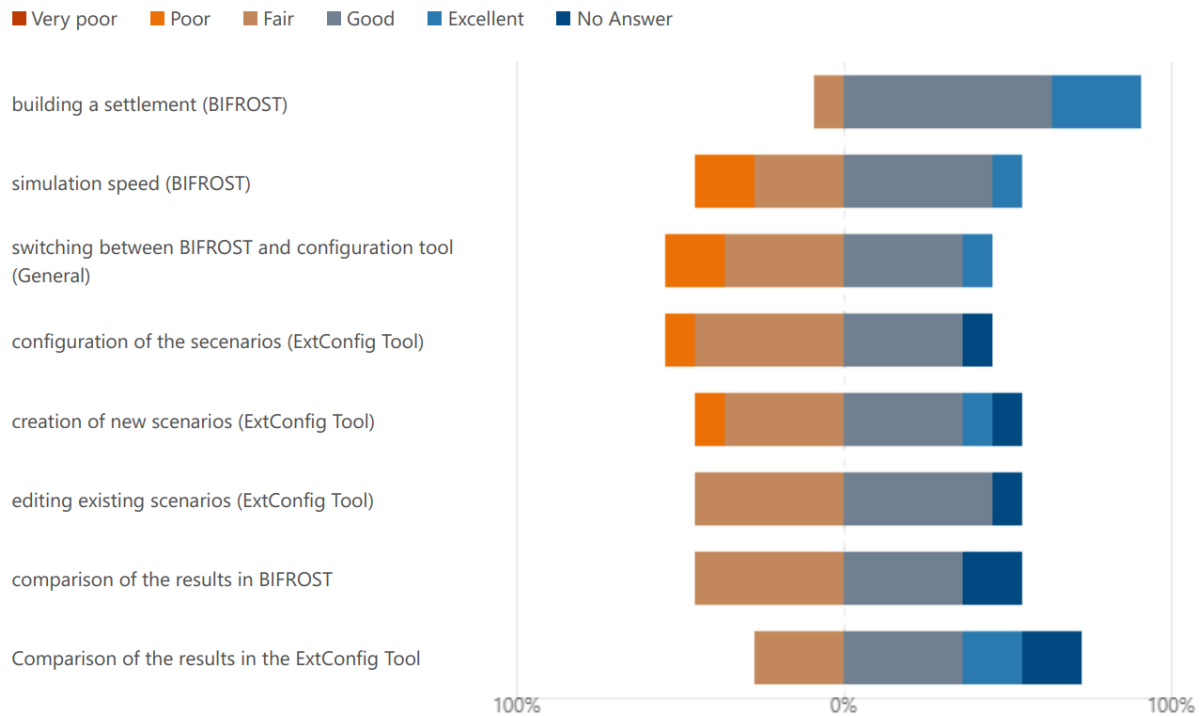

Figure 52: How do you like the different aspects of the configuration workflow?

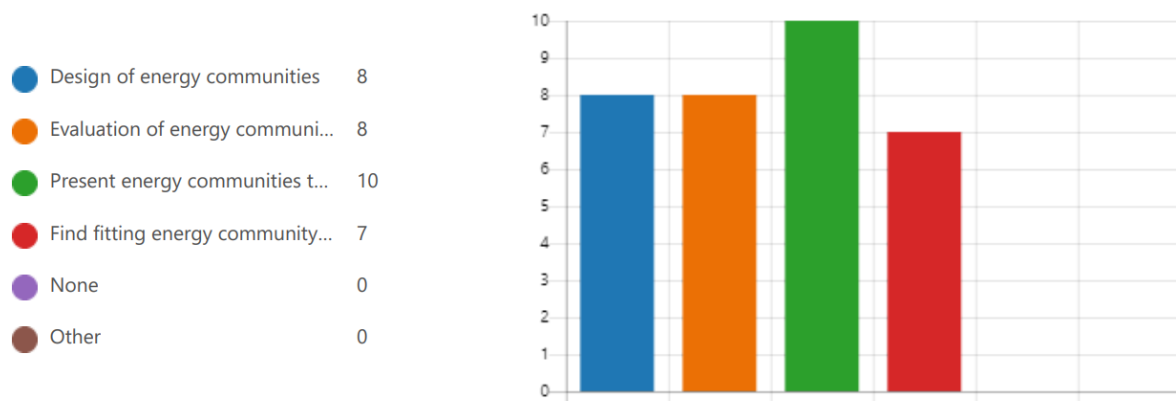

Figure 53: Where do you see the applications areas of the presented toolset (BIFROST + ExtConfig Tool)?

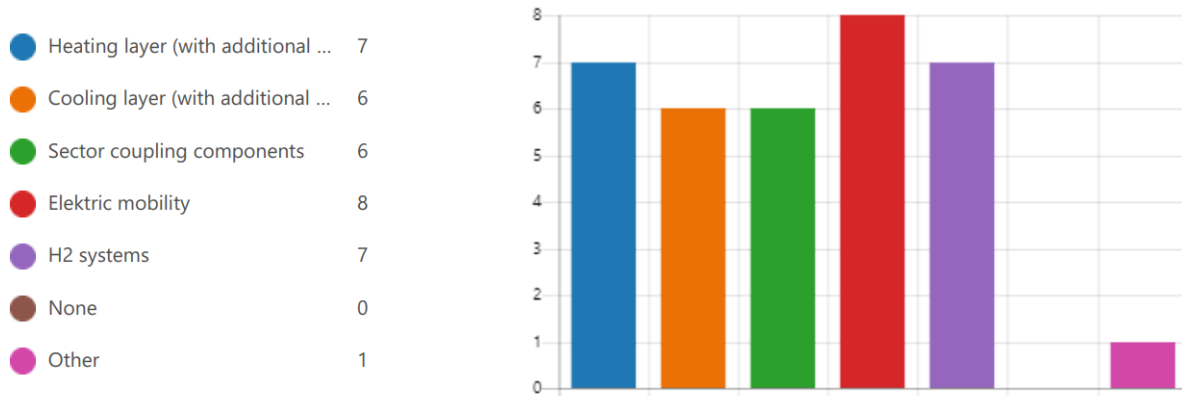

Figure 54: Which additional domains would improve the presented planing tool for you?

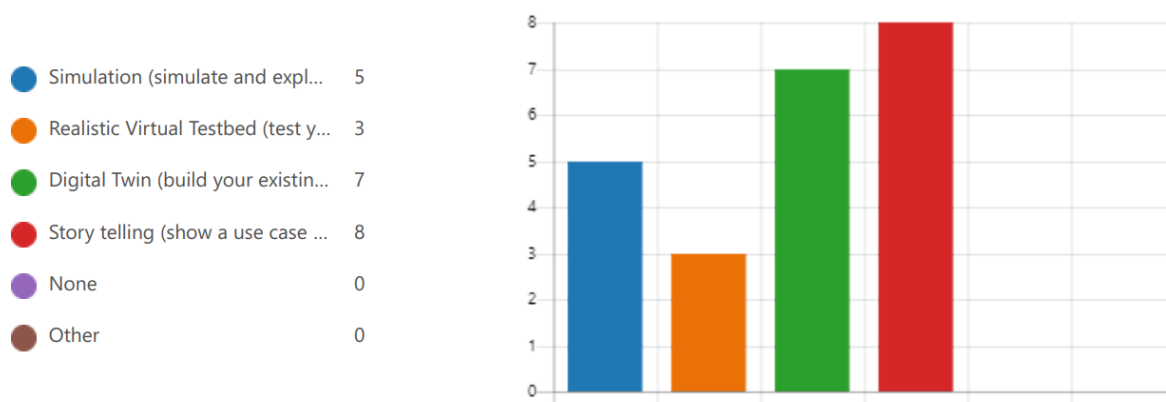

Figure 55: Where do you see additional application areas of BIFROST (regardless of the presented toolchain)?

Other Questions and their answers:

- What KPIs (Key Performance Indicators) are missing in the simulation? Can you elaborate on them?
 - Annual costs for the community members (including investment costs/LCOE of the community owned assets) to compare the economic situation of different scenarios.
 - Some more economic indicators such as payback period, rate of return, etc.
- Can you explain the need of the additional domains and your use cases for them? (In addition to Figure 54)
 - In Sweden district heating is an important part of most communities so to be able to use the tool in Sweden it is essential.
 - It recognises the overall direction of future energy systems.
 - E-mobility and micro-mobility layers are becoming more popular and may represent highly flexible demand (and generation with V2X) in the future.
 - Become closer to reality for energy community building.
- What did you like least about the CLUE planning tool approach?
 - Jumping between BIFROST and config

- A little complex before reading and knowing the tutorials.
- What did you like most about the CLUE planning tool approach?
 - It looks good and is fairly intuitive
 - A nice visual tool to interact with stakeholders
 - Clear, smart, neat.

The Answer of the Question “How intuitive is the handling of the BIFROST tool for you, after you finished the tutorial? (5 – very comfortable)” was answered with an average value 3.27. From this it can be seen that the developed planning approach is surly on a good way, but currently limited and only accessible to Tool experts. With the feedback from the project partner and further experience in working with the approach, the workflow will be improved and the capabilities of the Planning Tool will grow.

5 PROOF-OF-CONCEPT COMMUNITIES/CELLS STYRIA

5.1 Communication and Network

Local Energy Communities (LECs) will be an important element of the future energy system. These communities cooperate in the production, distribution, storage and supply of energy at local level with the aim to maximize the on-site generation and the self-consumption of renewable energy. New smart energy products and services will be explored, implemented and tested in the LECs.

5.1.1 Network and Gateway Concept in Demo Region Gasen

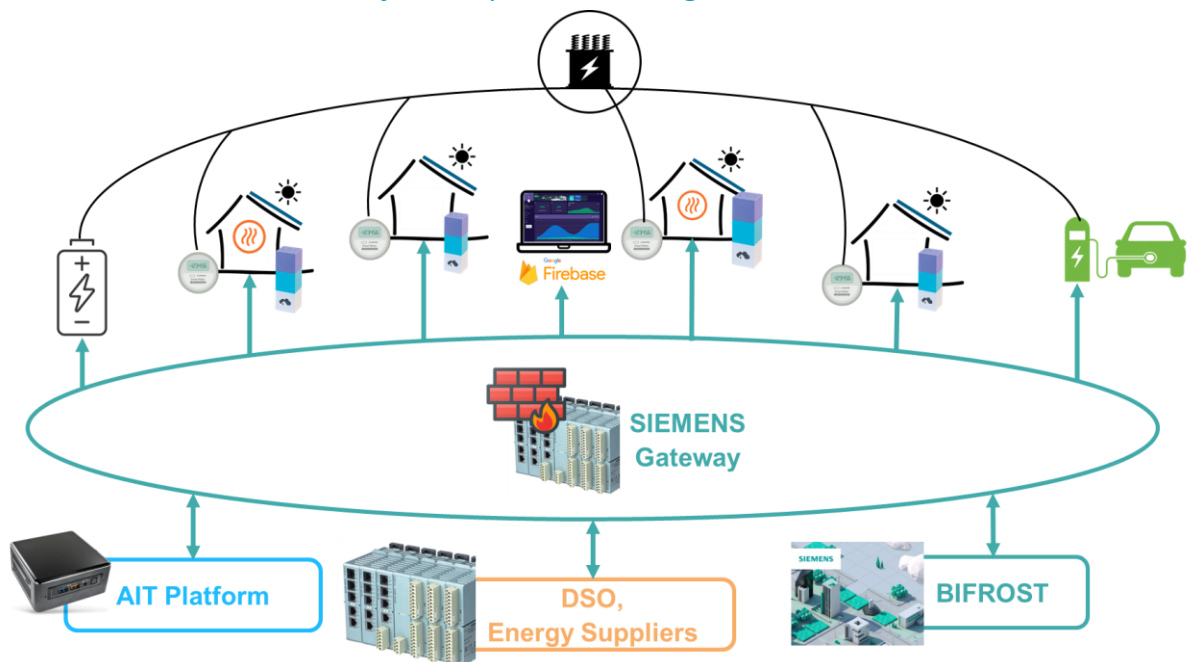

Information Technology (IT) and Operational Technology (OT) are well-protected networks in energy systems. Communication is only possible with own components or via strict firewalls. Measuring devices (smart meters) and load switching devices must be installed from the distribution system operator, because of secured communication protocols. These devices are normally protected against customer access. Money can be saved by using the existing home automation or other cloud systems. Therefore, a high secured energy management gateway (SIEMENS Gateway) should connect the energy system and the home automation. Some special management platform (AIT platform) should control the grid capacity and some additional services like P2P energy trading.

The communication between the home automation and the gateway must be based on typical protocols which are already available in these systems, like a RestAPIs or Websockets. The home automation system "Homee" uses websocket connection for the data access. RestAPIs can also be integrated very fast from tech-savvy customers in existing home automations.

All other components in the community use industrial standard protocols.

5.1.2 Network Topology and System Parts

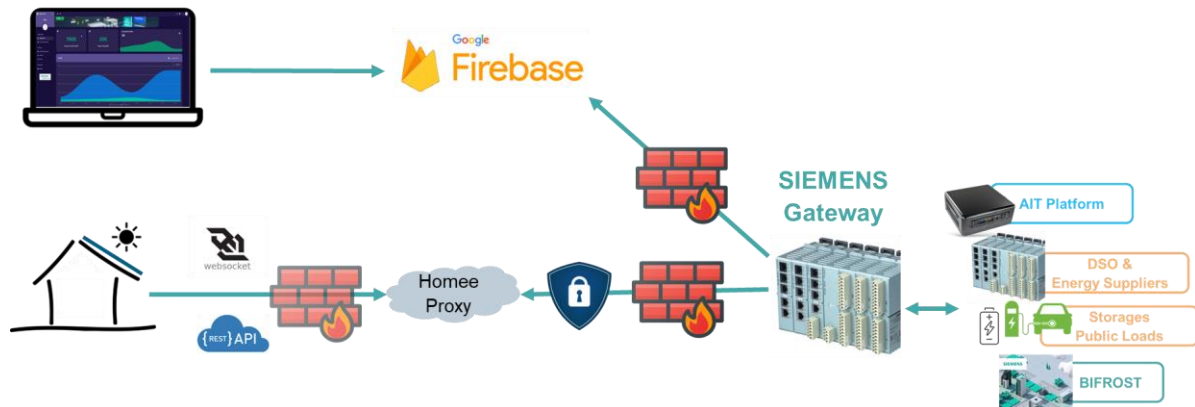

The architecture is structured into four parts:

- Energy System (AIT Platform, DSO & Energy Suppliers, Storages & Public Loads, Bifrost)
- Siemens Gateway
- Home Automation Systems
- User Interface

5.1.2.1 *AIT Rapid Deployment Platform*

Management services like Grid Capacity Management and P2P Energy Trading are running on this platform. These services are used to control and monitor the system and optimize the system for the energy community. This platform is developed by AIT and described in a separate section.

5.1.2.2 *Energy Storage & Public Loads*

Standard protocols like IEC60870-5-104, IEC61850 and Modbus TCP are used for the internal communication with energy storage like batteries, H2 storage or public loads like charging stations.

5.1.2.3 *Bifrost*

The Simulation Platform BIFROST is used to demonstrate some use cases for Energy Communities. The Open-Source platform is developed by Siemens and described in a separate section.

5.1.2.4 *DSO & Energy Suppliers*

Energy Management for DSO & Energy Suppliers are still handled on SICAM A8000.

SICAM A8000 RTU functionalities, CFC as programmable logic controller and standard protocols like IEC60870-5-104, IEC61850 and Modbus TCP, also with security features like TLS encryption are used by DSO & Energy Suppliers.

5.1.2.5 *Siemens Gateway*

The gateway is used as a firewall between the energy system and the prosumer/consumer in the low voltage grid, due to security risks.

Most of the protocols to the energy system are standard protocols, except the interface to the AIT platform. For this interface a common RestAPI is defined and will be mapped from/to the other interfaces. AJSON (JavaScript Object Notation) is used as transfer format for this protocol.

The “Home Automation System” and the “User Interface” is external located and reachable over the internet. The cloud “Google Firebase” is in use as a common database for the user interface, which is the only connection for the customer communication. “Homee” (home automation system) is connected via a RestAPI and websockets to the Siemens Gateway. This gateway is collecting measurements data from the customer’s home automation system and provide this data to the necessary system parts.

A single web application can be installed if some additional configurations are necessary.

5.1.2.6 *Home Automation Systems*

There shouldn’t be a specific home automation system which can be connected, because there are a lot of different systems. An easy setup should be possible to enable a connection to the energy community. RestAPIs (HTTPS) and Websockets are two of the most widely used protocols. Also MQTT with a json payload is often in use.

Examples:

- HOMEe has an own proxy to connect the home automation system to another system via Websocket, without open ports.
- Node-Red can be installed on a Raspberry Pi. There are Open-Source Nodes for RestAPI or Websocket connections.

5.1.2.7 *User Interface*

An interface is necessary to offer the customer setting options. Additionally, some dynamic changes can be done as well as shown some information about private and community data. A user registration and authentication are used for data privacy. The web site is hosted on a siemens server in an internal DMZ, where a customer can access via browser everywhere.

5.1.3 Network topology and System Party in Gasen

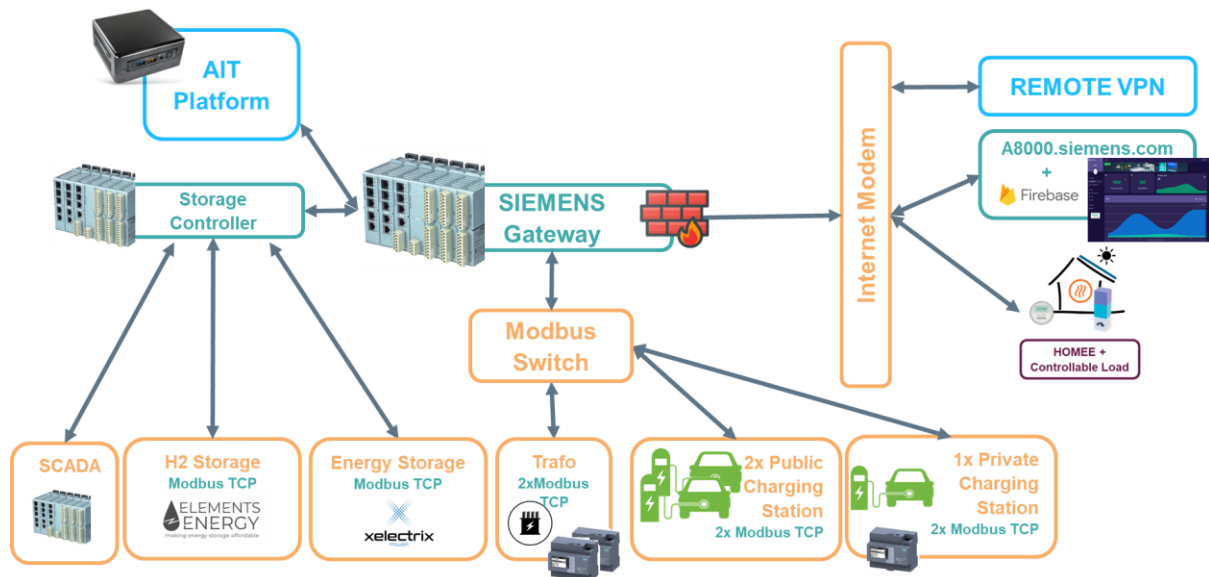

The field test includes the following units:

- SIEMENS Gateway
- AIT Platform
- Remote Access (AIT & SIEMENS)
- SCADA System
- User Interface
- HOME+ (incl. controllable load)
- Hydrogen Storage (H2 Storage)
- Energy Storage
- A8000 with Emergency Battery Algorithm
- Transformer Station
- Public Charging Station(s)
- Private Charging Station(s)

5.1.4 Used Protocols with Smart Home System

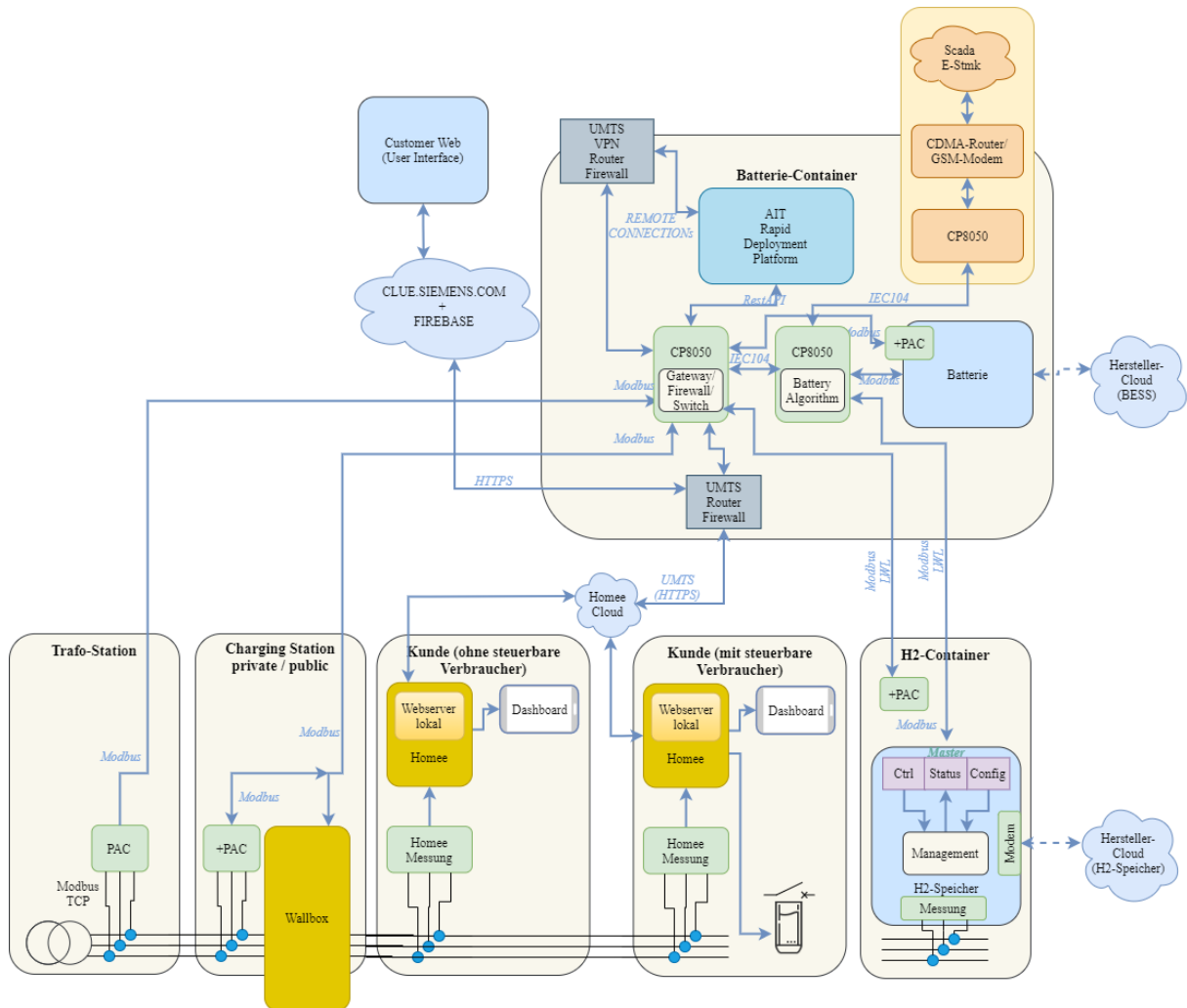

The field test includes the following communication channels from and to the SIEMENS Gateway.

AIT Platform => RestAPI

- Remote Access (AIT & SIEMENS) => HTTPS (TCP/IP)
- User Interface => RestAPI to Firebase (HTTPS)
- HOMEE (incl. controllable load) => WebSocket HTTPS
- Transformer Station => Modbus TCP
- Public Charging Station(s) => Modbus TCP
- Private Charging Station(s) => Modbus TCP
- A8000 with Emergency Battery Algorithm => IEC 60870-5-104

The A8000 with the Emergency Battery Algorithm includes following communication channels:

- SCADA System => IEC60870-5-104
- Hydrogen Storage (H2 Storage) => Modbus TCP
- Energy Storage => Modbus TCP

5.1.5 Siemens SICAM A8000 Gateway

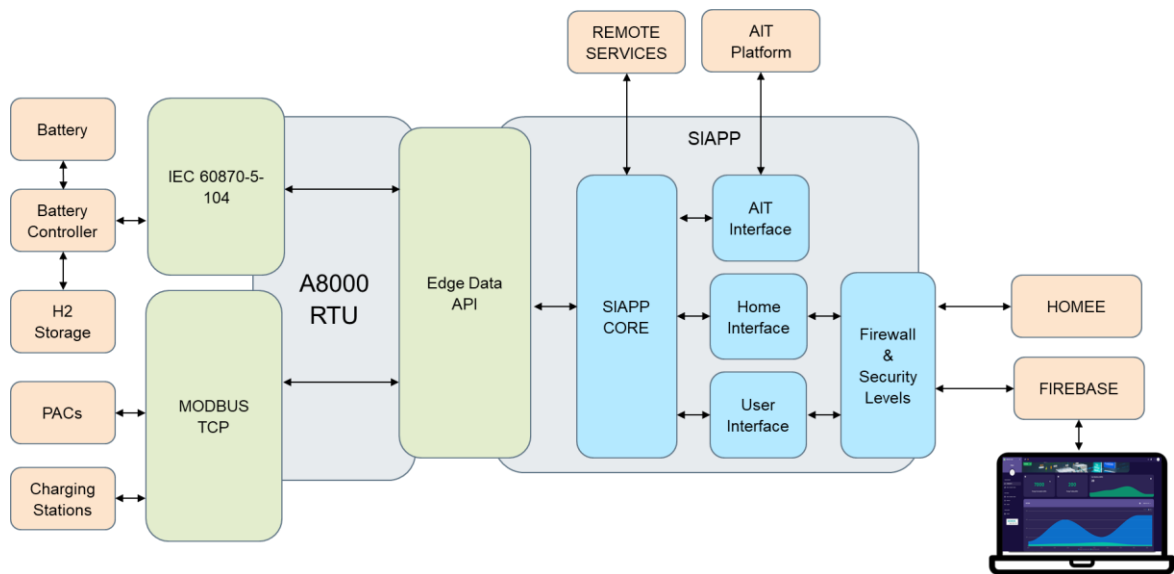

Gateway Architecture

The gateway consists of two main components. On the left side the RTU, which offers industrial protocols and interfaces. On the other side, a SIAPP that does provide non-standardized protocols. The SIAPP includes communication modules such as RestAPI, Websockets and MQTT. Smart home, IoT devices and the IoT cloud are connected to this gateway via these non-standard protocols.

To ensure security, these connections are encrypted and firewall protected.

5.1.6 SIAPP to Homee – 1st Connection Test

5.1.6.1 Setup

The SIAPP is connected over the internet with seven Homees (Smart Home Devices).

The Homee is a smart home device connected with a smart meter (Qubino or AEOTEK Smart Meter) and optional controllable loads. For a successful test, a correctly configured Homee and an internet connection on both sides are necessary. The smart home device receives the current measured values via a smart meter (AEOTEK Smart Meter). The measured values are accessible with the internal Homee-API and are available to the SIAPP for further processing.

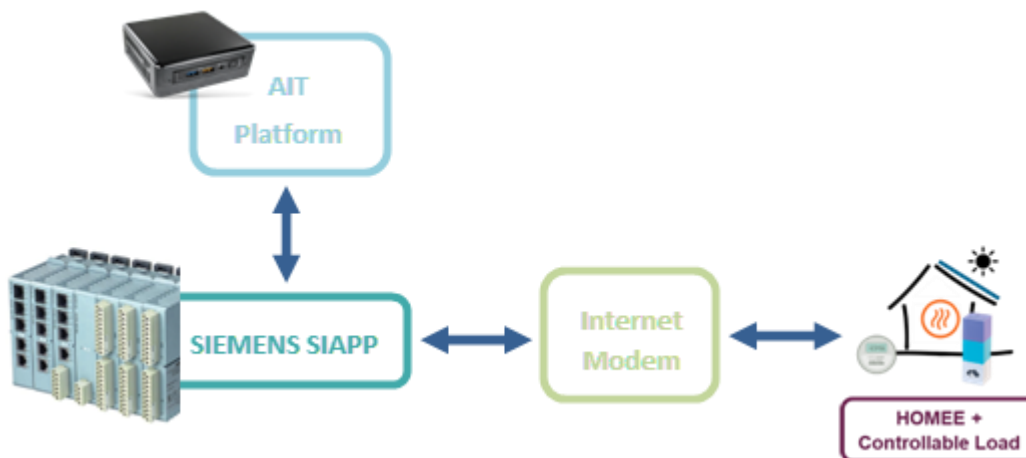

5.1.6.2 Test

```
2021-11-29 11:14:59 | /siapp_homee.cpp | operator() | 222 | Debug - Homee (00055113FF3: ) login successful: status code: 200 - OK
2021-11-29 11:15:00 | /siapp_homee.cpp | operator() | 336 | Debug - Connected to Homee (00055113FF3, ) websocket-API
2021-11-29 11:15:00 | /siapp_homee.cpp | operator() | 346 | Info - Send message to Homee (00055113FF3, ); GET:nodes
2021-11-29 11:15:00 | /siapp_homee.cpp | operator() | 338 | Debug - Homee (00055113FF3, ) WebSocket is closed
2021-11-29 11:15:00 | /siapp_homee.cpp | operator() | 392 | Info - Homee WebSocket is closed from siapp_core
Fan, Seifinger
2021-11-29 11:15:02 | /siapp_homee.cpp | operator() | 243 | Warning - Homee (0005516F9CF4: Fan, Seifinger) login: 401 - Unauthorized
Gasthaus Grabenbauer
2021-11-29 11:15:04 | /siapp_homee.cpp | operator() | 243 | Warning - Homee (0005516E7372: Gasthaus Grabenbauer) login: 401 - Unauthorized
Biomasse
2021-11-29 11:15:06 | /siapp_homee.cpp | operator() | 222 | Debug - Homee (000551134512: Biomasse) login successful: status code: 200 - OK
2021-11-29 11:15:06 | /siapp_homee.cpp | operator() | 336 | Debug - Connected to Homee (000551134512, Biomasse) websocket-API
2021-11-29 11:15:06 | /siapp_homee.cpp | operator() | 346 | Info - Send message to Homee (000551134512, Biomasse): GET:nodes
2021-11-29 11:15:06 | /siapp_homee.cpp | operator() | 338 | Debug - Homee (000551134512, Biomasse) WebSocket is closed
2021-11-29 11:15:06 | /siapp_homee.cpp | operator() | 392 | Info - Homee WebSocket is closed from siapp_core
Fan, P*rlz
2021-11-29 11:15:08 | /siapp_homee.cpp | operator() | 243 | Warning - Homee (0005516F9F60: Fan, P*rlz) login: 401 - Unauthorized
Fan, Schweiger
2021-11-29 11:15:10 | /siapp_homee.cpp | operator() | 222 | Debug - Homee (000551134536: Fan, Schweiger) login successful: status code: 200 - OK
2021-11-29 11:15:11 | /siapp_homee.cpp | operator() | 336 | Debug - Connected to Homee (000551134536, Fan, Schweiger) websocket-API
2021-11-29 11:15:11 | /siapp_homee.cpp | operator() | 346 | Info - Send message to Homee (000551134536, Fan, Schweiger): GET:nodes
2021-11-29 11:15:11 | /siapp_homee.cpp | operator() | 338 | Debug - Homee (000551134536, Fan, Schweiger) WebSocket is closed
2021-11-29 11:15:11 | /siapp_homee.cpp | operator() | 392 | Info - Homee WebSocket is closed from siapp_core
Gemeindeamt
2021-11-29 11:15:13 | /siapp_homee.cpp | operator() | 222 | Debug - Homee (0005511414FA: Gemeindeamt) login successful: status code: 200 - OK
2021-11-29 11:15:13 | /siapp_homee.cpp | operator() | 336 | Debug - Connected to Homee (0005511414FA, Gemeindeamt) websocket-API
2021-11-29 11:15:13 | /siapp_homee.cpp | operator() | 346 | Info - Send message to Homee (0005511414FA, Gemeindeamt): GET:nodes
2021-11-29 11:15:13 | /siapp_homee.cpp | operator() | 338 | Debug - Homee (0005511414FA, Gemeindeamt) WebSocket is closed
2021-11-29 11:15:13 | /siapp_homee.cpp | operator() | 392 | Info - Homee WebSocket is closed from siapp_core
Staanhaus
2021-11-29 11:15:15 | /siapp_homee.cpp | operator() | 243 | Warning - Homee (00055113454C: Staanhaus) login: 401 - Unauthorized
xx *C
```

5.1.6.3 Result

Nr.	Device ID	Result
1	0005510F9CF4	401 -> Device is not reachable
2	0005510E7372	401 -> Device is not reachable
3	000551134512	200 -> OK
4	0005510F9F6D	401 -> Device is not reachable
5	000551134530	200 -> OK
6	0005511141FA	200 -> OK
7	00055113454C	401 -> Device is not reachable

Figure 29: First Homee Connection Test Result

In the first test, only 3 out of 7 Homee devices are reachable. The reachable devices return the status code 200 and transmit the measurement data. The status code 401 is returned for unreachable devices. This indicates that no connection to the Homee device could be established. The device is offline and has no connection to the internet.

-> Establishing the connection on the physical device is necessary. The device "000551113FF3" is an internal test device and not part of the CLUE (Gasen) project. This device is also reachable.

5.1.7 SIAPP to Homee – 2nd Connection Test

5.1.7.1 Setup

The SIAPP is connected over the internet with seven Homees (Smart Home Devices).

The Homee is a smart home device connected with a smart meter (Qubino or AEOTEK Smart Meter) and optional controllable loads. For a successful test, a correctly configured Homee and an internet connection on both sides are necessary. The smart home device receives the current measured values via a smart meter (AEOTEK Smart Meter). The measured values are accessible with the internal Homee-API and are available to the SIAPP for further processing.

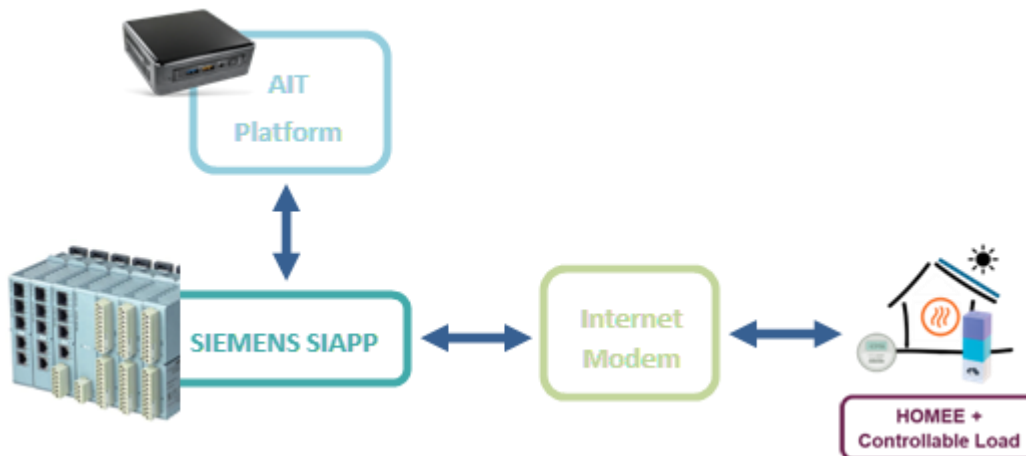

5.1.7.2 Test

```
2022-02-08 08:11:38 /AIT_REST.cpp AIT_Post_Data_Request 128 Info - POST to AIT-REST API (62.218.45.7)
2022-02-08 08:11:38 /AIT_REST.cpp operator() 163 Info - AIT POST successful: status code: 200 - OK
2022-02-08 08:11:40 /siapp_homee.cpp operator() 344 Debug - Homee (00051134512; Biomasse) login successful: status code: 200 - OK
2022-02-08 08:11:40 /siapp_homee.cpp operator() 477 Debug - Connected to Homee (00051134512; Biomasse) WebSocket-API
2022-02-08 08:11:40 /siapp_homee.cpp operator() 477 Debug - Send message to Homee (00051134512; Biomasse): GET:nodes
2022-02-08 08:11:40 /siapp_homee.cpp operator() 434 Info - Got measurements from Homee (Biomasse)
2022-02-08 08:11:40 /siapp_homee.cpp operator() 461 Debug - Homee (00051134512; Biomasse) WebSocket is closed
2022-02-08 08:11:40 /siapp_homee.cpp operator() 523 Debug - Homee WebSocket is closed from siapp_core
2022-02-08 08:11:41 /siapp_homee.cpp operator() 345 Warning - Homee (00051093960; Fam. Pohl) login: 401 - Unauthorized
2022-02-08 08:11:40 /siapp_homee.cpp operator() 344 Debug - Homee (00051093960; Fam. Seilinger) login successful: status code: 200 - OK
2022-02-08 08:11:40 /siapp_homee.cpp operator() 467 Debug - Connected to Homee (00051093960; Fam. Seilinger) WebSocket-API
2022-02-08 08:11:40 /siapp_homee.cpp operator() 477 Debug - Send message to Homee (00051093960; Fam. Seilinger): GET:nodes
2022-02-08 08:11:40 /siapp_homee.cpp operator() 434 Info - Got measurements from Homee (Fam. Seilinger)
2022-02-08 08:11:40 /siapp_homee.cpp operator() 461 Debug - Homee (00051093960; Fam. Seilinger) WebSocket is closed
2022-02-08 08:11:40 /siapp_homee.cpp operator() 523 Debug - Homee WebSocket is closed from siapp_core
2022-02-08 08:11:53 /siapp_homee.cpp operator() 345 Warning - Homee (00051134500; Staanthaus) login: 401 - Unauthorized
2022-02-08 08:12:20 /siapp_homee.cpp operator() 344 Debug - Homee (00051134514; Geesindmaat) login successful: status code: 200 - OK
2022-02-08 08:12:21 /siapp_homee.cpp operator() 467 Debug - Connected to Homee (00051134514; Geesindmaat) WebSocket-API
2022-02-08 08:12:21 /siapp_homee.cpp operator() 477 Debug - Send message to Homee (00051134514; Geesindmaat): GET:nodes
2022-02-08 08:12:21 /siapp_homee.cpp operator() 434 Info - Got measurements from Homee (Geesindmaat)
2022-02-08 08:12:21 /siapp_homee.cpp operator() 461 Debug - Homee (00051134514; Geesindmaat) WebSocket is closed
2022-02-08 08:12:21 /siapp_homee.cpp operator() 523 Debug - Homee WebSocket is closed from siapp_core
2022-02-08 08:12:27 /siapp_homee.cpp operator() 344 Debug - Homee (000510E7772; Gasthaus Grabenbauer) login successful: status code: 200 - OK
2022-02-08 08:12:27 /siapp_homee.cpp operator() 467 Debug - Connected to Homee (000510E7772; Gasthaus Grabenbauer) WebSocket-API
2022-02-08 08:12:27 /siapp_homee.cpp operator() 477 Debug - Send message to Homee (000510E7772; Gasthaus Grabenbauer): GET:nodes
2022-02-08 08:12:27 /siapp_homee.cpp operator() 434 Info - Got measurements from Homee (Gasthaus Grabenbauer)
2022-02-08 08:12:28 /siapp_homee.cpp operator() 461 Debug - Homee (000510E7772; Gasthaus Grabenbauer) WebSocket is closed
2022-02-08 08:12:28 /siapp_homee.cpp operator() 523 Debug - Homee WebSocket is closed from siapp_core
2022-02-08 08:12:28 /siapp_homee.cpp operator() 344 Debug - Homee (00051134538; Fam. Schaejger) login successful: status code: 200 - OK
2022-02-08 08:12:28 /siapp_homee.cpp operator() 467 Debug - Connected to Homee (00051134538; Fam. Schaejger) WebSocket-API
2022-02-08 08:12:28 /siapp_homee.cpp operator() 477 Debug - Send message to Homee (00051134538; Fam. Schaejger): GET:nodes
2022-02-08 08:12:28 /siapp_homee.cpp operator() 434 Info - Got measurements from Homee (Fam. Schaejger)
2022-02-08 08:12:28 /siapp_homee.cpp operator() 461 Debug - Homee (00051134538; Fam. Schaejger) WebSocket is closed
2022-02-08 08:12:28 /siapp_homee.cpp operator() 523 Debug - Homee WebSocket is closed from siapp_core
2022-02-08 08:12:38 /AIT_REST.cpp AIT_Post_Data_Request 128 Info - POST to AIT-REST API (62.218.45.7)
2022-02-08 08:12:38 /AIT_REST.cpp operator() 163 Info - AIT POST successful: status code: 200 - OK
2022-02-08 08:12:40 /siapp_homee.cpp operator() 344 Debug - Homee (00051134512; Biomasse) login successful: status code: 200 - OK
2022-02-08 08:12:41 /siapp_homee.cpp operator() 477 Debug - Connected to Homee (00051134512; Biomasse) WebSocket-API
2022-02-08 08:12:41 /siapp_homee.cpp operator() 477 Debug - Send message to Homee (00051134512; Biomasse): GET:nodes
2022-02-08 08:12:41 /siapp_homee.cpp operator() 434 Info - Got measurements from Homee (Biomasse)
2022-02-08 08:12:41 /siapp_homee.cpp operator() 461 Debug - Homee (00051134512; Biomasse) WebSocket is closed
2022-02-08 08:12:41 /siapp_homee.cpp operator() 523 Debug - Homee WebSocket is closed from siapp_core
2022-02-08 08:12:42 /siapp_homee.cpp operator() 345 Warning - Homee (00051093960; Fam. Pohl) login: 401 - Unauthorized
2022-02-08 08:12:42 /siapp_homee.cpp operator() 344 Debug - Homee (00051093960; Fam. Seilinger) login successful: status code: 200 - OK
2022-02-08 08:12:42 /siapp_homee.cpp operator() 467 Debug - Connected to Homee (00051093960; Fam. Seilinger) WebSocket-API
2022-02-08 08:12:42 /siapp_homee.cpp operator() 477 Debug - Send message to Homee (00051093960; Fam. Seilinger): GET:nodes
```

5.1.7.3 Result

Nr.	Device ID	Result
1	0005510F9CF4	200 -> OK
2	0005510E7372	200 -> OK
3	000551134512	200 -> OK
4	0005510F9F6D	401 -> Device is not reachable
5	000551134530	200 -> OK
6	0005511141FA	200 -> OK
7	00055113454C	401 -> Device is not reachable

In the second test, 5 out of 7 Homee devices are reachable. The reachable devices return the status code 200 and transmit the measurement data. The status code 401 is returned for unreachable devices. This indicates that no connection to the Homee device could be established. The device is offline and has no connection to the internet.

-> Establishing the connection on the physical device is necessary. Homee "0005510F9CF4", "0005510E7372" are online again. A closer location to the WiFi improved the network connection.

5.1.8 SIAPP to Homee – 3rd Connection Test

5.1.8.1 Setup

The SIAPP is connected over the internet with seven Homees (Smart Home Devices).

The Homee is a smart home device connected with a smart meter (AEOTEC Smart Meter) and optional controllable loads. For a successful test, a correctly configured Homee and an internet connection on both sides are necessary. The smart home device receives the current measured values via a smart meter (AEOTEC Smart Meter). The measured values are accessible with the internal Homee-API and are available to the SIAPP for further processing.

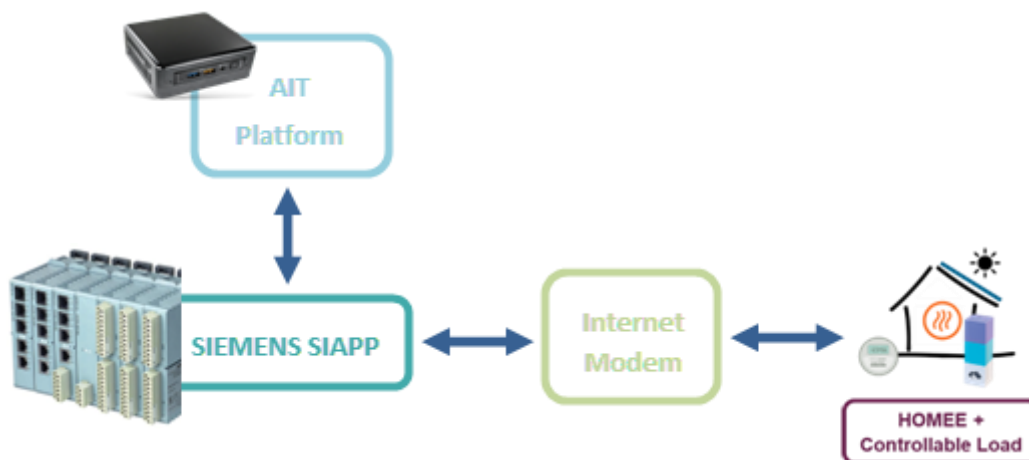

5.1.8.2 Test

```
root@runc: ~# /opt/siapp_core --homee --subscribe-all --loglevel 5 &
[1] 24051
root@runc: ~# 2022-03-25 12:08:08 | /siapp_core.cpp | main | 758 | Notice - siapp_core 3.3.0 (build date: Mar 25 2022 12:03:00)
2022-03-25 12:08:08 | /siapp_core.cpp | main | 759 | Notice - Start Time: Fri Mar 25 12:08:08 2022
2022-03-25 12:08:08 | /siapp_core.cpp | main | 762 | Notice - Limit stack to 131068

[1]+ Done /opt/siapp_core --homee --subscribe-all --loglevel 5
root@runc: ~# stop
root@runc: ~# tail -F /var/log/siapp_core_2022-03-25.log
2022-03-25 12:08:08 | /siapp_core.cpp | main | 758 | Notice - siapp_core 3.3.0 (build date: Mar 25 2022 12:03:00)
2022-03-25 12:08:08 | /siapp_core.cpp | main | 759 | Notice - Start Time: Fri Mar 25 12:08:08 2022
2022-03-25 12:08:08 | /siapp_core.cpp | main | 762 | Notice - Limit stack to 131068
2022-03-25 12:08:08 | /siapp_core.cpp | main | 768 | Notice - siapp_core is running in daemon mode
2022-03-25 12:08:08 | /mqtt.cpp | mosquitto_init_connect | 76 | Notice - MQTT Client connected to 127.0.0.1 on port 1883
2022-03-25 12:08:08 | /http_listener.cpp | operator() | 92 | Notice - Starting to listen [127.0.0.1] and wait for clients...
2022-03-25 12:08:57 | /siapp_homee.cpp | operator() | 434 | Warning - Homee {00055113454C: Stoamibauss} login: 401 - Unauthorized
2022-03-25 12:09:48 | /siapp_homee.cpp | operator() | 434 | Warning - Homee {0005510F9CF4: Fam. Seitzinger} login: 401 - Unauthorized
2022-03-25 12:09:50 | /siapp_homee.cpp | operator() | 434 | Warning - Homee {00055113454C: Stoamibauss} login: 401 - Unauthorized
2022-03-25 12:10:44 | /siapp_homee.cpp | operator() | 434 | Warning - Homee {00055113454C: Stoamibauss} login: 401 - Unauthorized
2022-03-25 12:11:38 | /siapp_homee.cpp | operator() | 434 | Warning - Homee {00055113454C: Stoamibauss} login: 401 - Unauthorized
2022-03-25 12:12:32 | /siapp_homee.cpp | operator() | 434 | Warning - Homee {00055113454C: Stoamibauss} login: 401 - Unauthorized
2022-03-25 12:13:25 | /siapp_homee.cpp | operator() | 434 | Warning - Homee {00055113454C: Stoamibauss} login: 401 - Unauthorized
```

5.1.8.3 Result

Nr.	Device ID	Result
1	0005510F9CF4	200 -> OK
2	0005510E7372	200 -> OK
3	000551134512	200 -> OK
4	0005510F9F6D	401 -> Device is not reachable
5	000551134530	200 -> OK
6	0005511141FA	200 -> OK
7	00055113454C	200 -> OK

Figure 32: Second Homee Connection Test Result

In the third test, 6 out of 7 Homee devices are reachable. The reachable devices return the status code 200 and transmit the measurement data. The status code 401 is returned for unreachable devices. This indicates that no connection to the Homee device could be established. The device is offline and has no connection to the internet.

5.1.9 Homee Measurement Values Test

5.1.9.1 Setup

The SIAPP is via a modem connected to the internet. This allows a connection to the Smart Home (Homee) and the measured values. These values should be retrievable and valid.

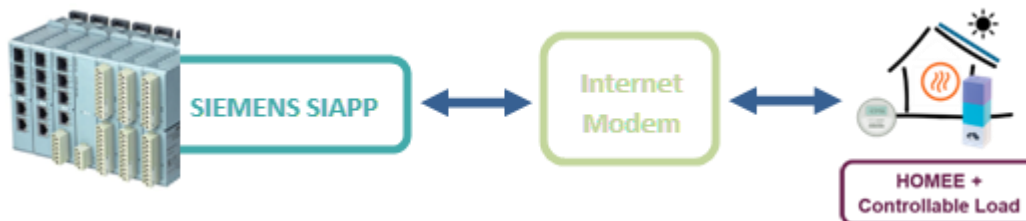

5.1.9.2 Test

```
ID: -1 - homee
2021-11-30 09:23:14 | /siapp_homee.cpp | operator() | 303 | Debug - Homee (000551130512, Siseasse) WebSocket is closed
2021-11-30 09:23:14 | /siapp_homee.cpp | operator() | 425 | Info - Homee WebSocket is closed from siapp_core
2021-11-30 09:23:15 | /siapp_homee.cpp | operator() | 273 | Warning - Homee (0005518F9F6D, Fam, Pwizl) login: 481 - Unauthorized
2021-11-30 09:23:18 | /siapp_homee.cpp | operator() | 252 | Debug - Homee (000551130530, Fam, Schweiger) login successful: status code: 200 - OK
2021-11-30 09:23:18 | /siapp_homee.cpp | operator() | 309 | Debug - Connected to Homee (000551130530, Fam, Schweiger) WebSocket-API
2021-11-30 09:23:18 | /siapp_homee.cpp | operator() | 379 | Info - Send message to Homee (000551130530, Fam, Schweiger): GET:nodes

ID: 1 - Hausleitung
TotalAccumulatedEnergyUse 0: 799.123 kWh
AccumulatedEnergyUse 1: 798.094 kWh
AccumulatedEnergyUse 2: 555.213 kWh
AccumulatedEnergyUse 3: -518.184 kWh
TotalCurrentEnergyUse 0: 619.793 W
TotalVoltage 0: 234.749 V
TotalCurrent 0: 4.172 A
CurrentEnergyUse 1: 51.61 W
Voltage 1: 234.750 V
Current 1: 0.22 A
CurrentEnergyUse 2: 552.085 W
Voltage 2: 234.392 V
Current 2: 2.37 A
CurrentEnergyUse 3: 16.316 W
Voltage 3: 234.386 V
Current 3: 0.208 A
2021-11-30 09:23:19 | /siapp_homee.cpp | operator() | 303 | Debug - Homee (000551130530, Fam, Schweiger) WebSocket is closed
2021-11-30 09:23:19 | /siapp_homee.cpp | operator() | 425 | Info - Homee WebSocket is closed from siapp_core
2021-11-30 09:23:21 | /siapp_homee.cpp | operator() | 252 | Debug - Homee (000551141FA, Gemeindeamt) login successful: status code: 200 - OK
2021-11-30 09:23:21 | /siapp_homee.cpp | operator() | 309 | Debug - Connected to Homee (000551141FA, Gemeindeamt) WebSocket-API
2021-11-30 09:23:21 | /siapp_homee.cpp | operator() | 379 | Info - Send message to Homee (000551141FA, Gemeindeamt): GET:nodes

ID: 1 - Hausleitung Gemeindeamt
TotalAccumulatedEnergyUse 0: 2095.26 kWh
AccumulatedEnergyUse 1: 548.634 kWh
AccumulatedEnergyUse 2: 632.056 kWh
AccumulatedEnergyUse 3: 922.573 kWh
TotalCurrentEnergyUse 0: 937.966 W
TotalVoltage 0: 234.92 V
TotalCurrent 0: 5.452 A
CurrentEnergyUse 1: 181.275 W
Voltage 1: 234.92 V
Current 1: 0.774 A
CurrentEnergyUse 2: 559.986 W
Voltage 2: 233.631 V
Current 2: 2.456 A
CurrentEnergyUse 3: 195.897 W
Voltage 3: 233.619 V
Current 3: 0.84 A
ID: -1 - homee
2021-11-30 09:23:21 | /siapp_homee.cpp | operator() | 303 | Debug - Homee (000551141FA, Gemeindeamt) WebSocket is closed
2021-11-30 09:23:21 | /siapp_homee.cpp | operator() | 425 | Info - Homee WebSocket is closed from siapp_core
```

5.1.9.3 Result

After the established connection, the measurement values are accessible. All reachable Homees provide valid measurement values.

5.1.10 Homee AIT json-value Test

5.1.10.1 Setup

The SIAPP is via a modem connected to the internet. This allows a connection to the Smart Home (Homee) and the measured values. These values should be converted into a json to provide the data to the AIT controller.

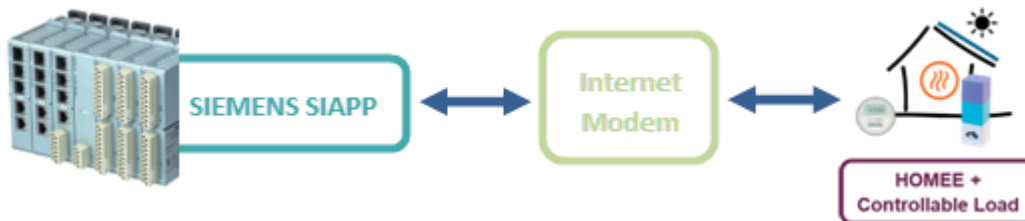

5.1.10.2 Test

```
2022-11-30 18:57:40 /sIapp_homee.cpp operator() 688 Debug - Homee (000551130538, Faam, Schweiger) websocket is closed
2022-11-30 18:57:46 /sIapp_homee.cpp operator() 527 Info - Homee websocket is closed from siapp_core
2022-11-30 18:57:48 /sIapp_homee.cpp operator() 375 Warning - Homee (000551140940, Faam, Pflizl) login: 401 - unauthorized
2022-11-30 18:57:50 /sIapp_homee.cpp operator() 354 Debug - Homee (000551130538, Faam, Schweiger) login successful; status code: 200 - OK
2022-11-30 18:57:51 /sIapp_homee.cpp operator() 471 Debug - Connected to Homee (000551130538, Faam, Schweiger) websocket-API
2022-11-30 18:57:51 /sIapp_homee.cpp operator() 481 Info - Send message to Homee (000551130538, Faam, Schweiger): GET:nodes
ID: 3 - Beller (vor Thyristorsteller)
ID: -1 - Homee
ID: 1 - Hausleitung
{"device": "000551130538", "name": "TotalAccumulatedEnergyUse_", "time": 1638266217, "type": "energy", "unit": "kWh", "value": 797.404899999999999999}
{"device": "000551130538", "name": "CumulatedEnergyUse_", "time": 1638266218, "type": "energy", "unit": "kWh", "value": 750.500000000000000000}
{"device": "000551130538", "name": "CumulatedEnergyUse_", "time": 1638266218, "type": "energy", "unit": "kWh", "value": 556.507999999999999999}
{"device": "000551130538", "name": "TotalCurrentEnergyUse_", "time": 1638266218, "type": "energy", "unit": "kWh", "value": 518.600000000000000000}
{"device": "000551130538", "name": "TotalVoltage_", "time": 1638266217, "type": "voltage", "unit": "V", "value": 235.852}
{"device": "000551130538", "name": "TotalCurrent_", "time": 1638266217, "type": "current", "unit": "A", "value": 12.74}
{"device": "000551130538", "name": "CurrentEnergyUse_", "time": 1638266207, "type": "energy", "unit": "Wh", "value": 128.332}
{"device": "000551130538", "name": "Voltage_", "time": 1638266217, "type": "voltage", "unit": "V", "value": 235.852}
{"device": "000551130538", "name": "Current_", "time": 1638266207, "type": "current", "unit": "A", "value": 8.538000000000000000}
{"device": "000551130538", "name": "CurrentEnergyUse_", "time": 1638265927, "type": "energy", "unit": "Wh", "value": 2641.4320000000000000}
{"device": "000551130538", "name": "Voltage_", "time": 1638266217, "type": "voltage", "unit": "V", "value": 234.0870000000000000}
{"device": "000551130538", "name": "Current_", "time": 1638266217, "type": "current", "unit": "A", "value": 11.360}
{"device": "000551130538", "name": "CurrentEnergyUse_", "time": 1638266192, "type": "energy", "unit": "Wh", "value": 168.887999999999999999}
{"device": "000551130538", "name": "Voltage_", "time": 1638266217, "type": "voltage", "unit": "V", "value": 235.7380000000000000}
{"device": "000551130538", "name": "Current_", "time": 1638266218, "type": "current", "unit": "A", "value": 8.878}
2022-11-30 18:57:51 /sIapp_homee.cpp operator() 488 Debug - Homee (000551130538, Faam, Schweiger) websocket is closed
2022-11-30 18:57:51 /sIapp_homee.cpp operator() 527 Info - Homee websocket is closed from siapp_core
2022-11-30 18:57:52 /sIapp_homee.cpp operator() 354 Debug - Homee (0005511411FA, Gemeindeamt) login successful; status code: 200 - OK
2022-11-30 18:57:53 /sIapp_homee.cpp operator() 471 Debug - Connected to Homee (0005511411FA, Gemeindeamt) websocket-API
2022-11-30 18:57:53 /sIapp_homee.cpp operator() 481 Info - Send message to Homee (0005511411FA, Gemeindeamt): GET:nodes
ID: 1 - Hausleitung Gemeindeamt
{"device": "0005511411FA", "name": "TotalAccumulatedEnergyUse_", "time": 1638266217, "type": "energy", "unit": "kWh", "value": 2086.7570000000000000}
{"device": "0005511411FA", "name": "CumulatedEnergyUse_", "time": 1638266218, "type": "energy", "unit": "kWh", "value": 508.9500000000000000}
{"device": "0005511411FA", "name": "CumulatedEnergyUse_", "time": 1638266218, "type": "energy", "unit": "kWh", "value": 632.87}
{"device": "0005511411FA", "name": "TotalCurrentEnergyUse_", "time": 1638266218, "type": "energy", "unit": "kWh", "value": 322.9320000000000000}
{"device": "0005511411FA", "name": "TotalVoltage_", "time": 1638266217, "type": "voltage", "unit": "V", "value": 235.4280000000000000}
{"device": "0005511411FA", "name": "TotalCurrent_", "time": 1638266217, "type": "current", "unit": "A", "value": 10.469999999999999999}
{"device": "0005511411FA", "name": "CurrentEnergyUse_", "time": 1638266072, "type": "energy", "unit": "Wh", "value": 138.4100000000000000}
{"device": "0005511411FA", "name": "Voltage_", "time": 1638266217, "type": "voltage", "unit": "V", "value": 235.4280000000000000}
{"device": "0005511411FA", "name": "Current_", "time": 1638266218, "type": "current", "unit": "A", "value": 8.935000000000000000}
{"device": "0005511411FA", "name": "CurrentEnergyUse_", "time": 1638265607, "type": "energy", "unit": "Wh", "value": 659.9800000000000000}
{"device": "0005511411FA", "name": "Voltage_", "time": 1638266218, "type": "voltage", "unit": "V", "value": 234.5219999999999999}
{"device": "0005511411FA", "name": "Current_", "time": 1638266218, "type": "current", "unit": "A", "value": 11.830000000000000000}
{"device": "0005511411FA", "name": "CurrentEnergyUse_", "time": 1638266207, "type": "energy", "unit": "Wh", "value": 270.8190000000000000}
{"device": "0005511411FA", "name": "Voltage_", "time": 1638266218, "type": "voltage", "unit": "V", "value": 234.488}
{"device": "0005511411FA", "name": "Current_", "time": 1638266207, "type": "current", "unit": "A", "value": 11.187}
ID: -1 - Homee
```

5.1.10.3 Result

All values are converted to a json format. The json-key 'name' is wrong. Characters are missing. -> Fixed in the next version.

5.1.11 Homee – AEOTEC Data Test

5.1.11.1 Setup

The SIAPP is via a modem connected to the internet. This allows a connection to the Smart Home (AEOTEC) and the measured values. These values should be retrievable and valid.

All measured values are transmitted from the AEOTEC Smart Meter to the Homee.

The received values are stored in an internal database of Homee.

The same values, which are used for this project, are accessible from the Homee Webserver.

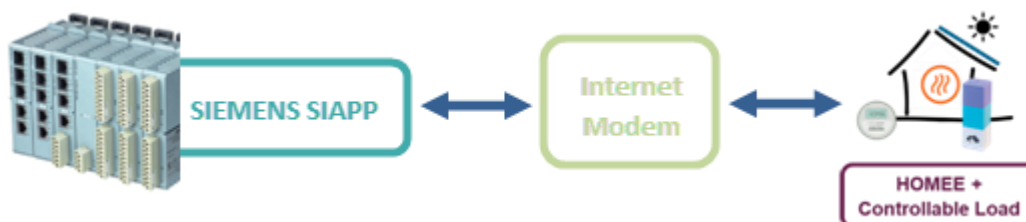

5.1.12 Test Homee 000551134512 “Biomasse” power / week

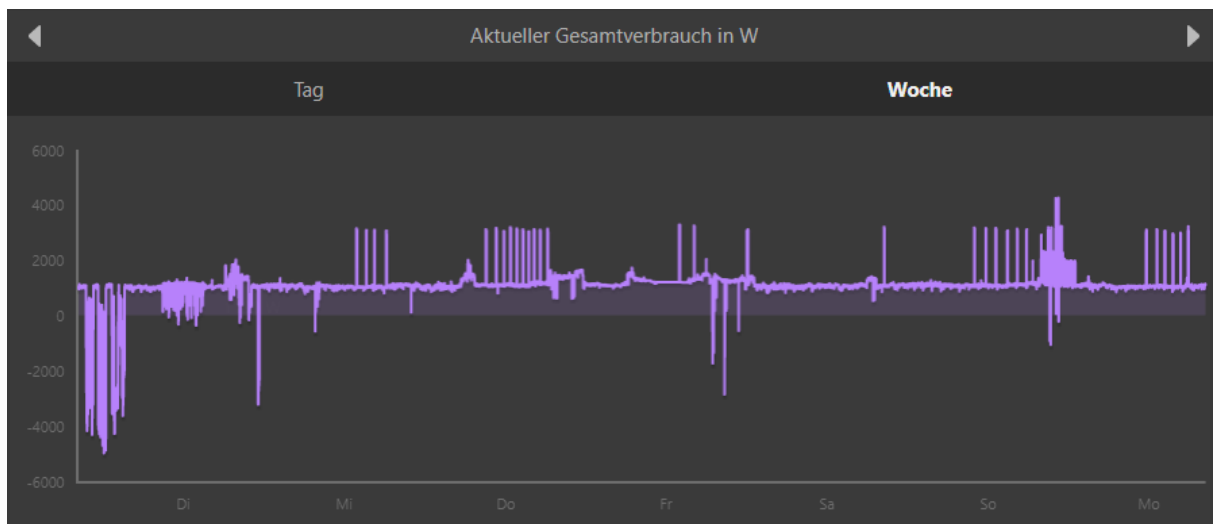

5.1.12.1 Result

The measured values are from the web-interface accessible. The measurement data over the week are valid.

5.1.13 Test Homee 000551134512 "Biomasse" power / day

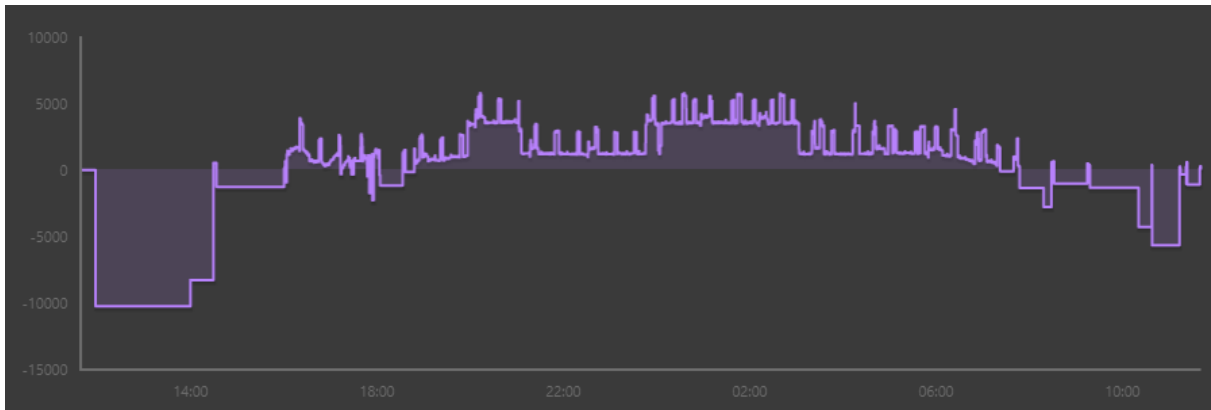

5.1.13.1 Result

The measurement data are accessible. The measurement holds at a certain value, the consumption does not change.

5.1.14 Test Homee 000551134512 "Biomasse" current / day

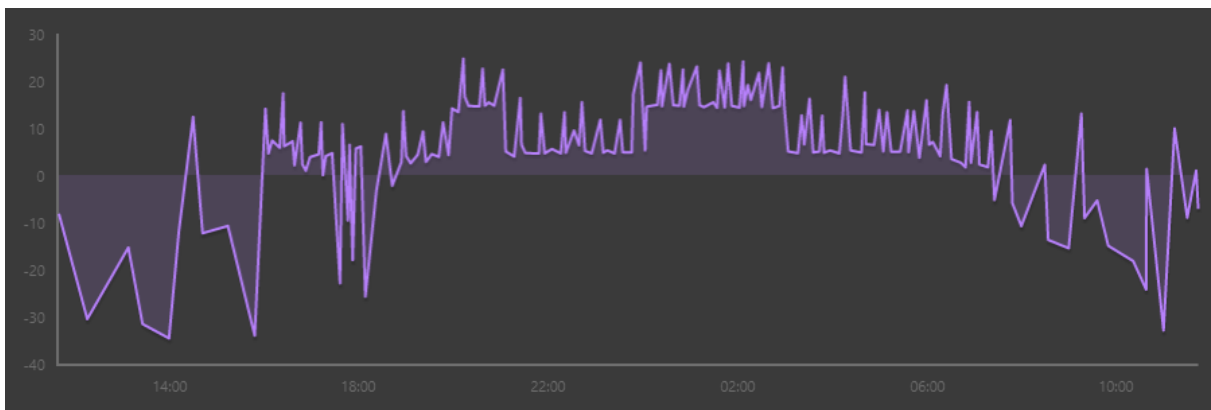

5.1.14.1 Result

The measured values are from the web-interface accessible. The measurement data are accessible, but there are data failures. The measurement holds at a certain value, the consumption does not change. At the same time (12:00-14:00), the current (ampere) changes on the same phase. Which should also result in a change in power (watt). This value does not show any change. Consequently, data points are missing in the measurement or in the database from Homee.

5.1.15 Test Homee 0005511141FA "Gemeindeamt" power / week

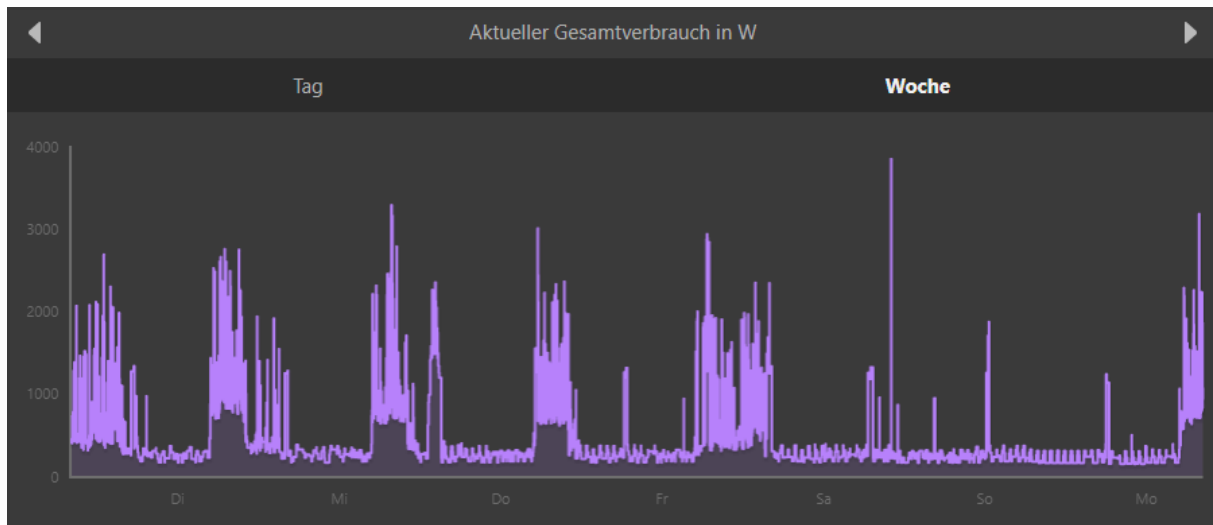

5.1.15.1 Result

The measured values are from the web-interface accessible. The measurement data over the week are valid. The peak of power between Saturday and Sunday is noticeable.

5.1.16 Test Homee 000551134530 "Schweiger" power / week



5.1.16.1 Result

The measured values are from the web-interface accessible. The measurement data are accessible, but there are data failures. The measurement holds at a certain value (10:00), the consumption does not change. Data points are missing in the measurement or in the database from Homee.

5.1.17 Test Homee 0005510E7372 "Grabenbauer" energy / month

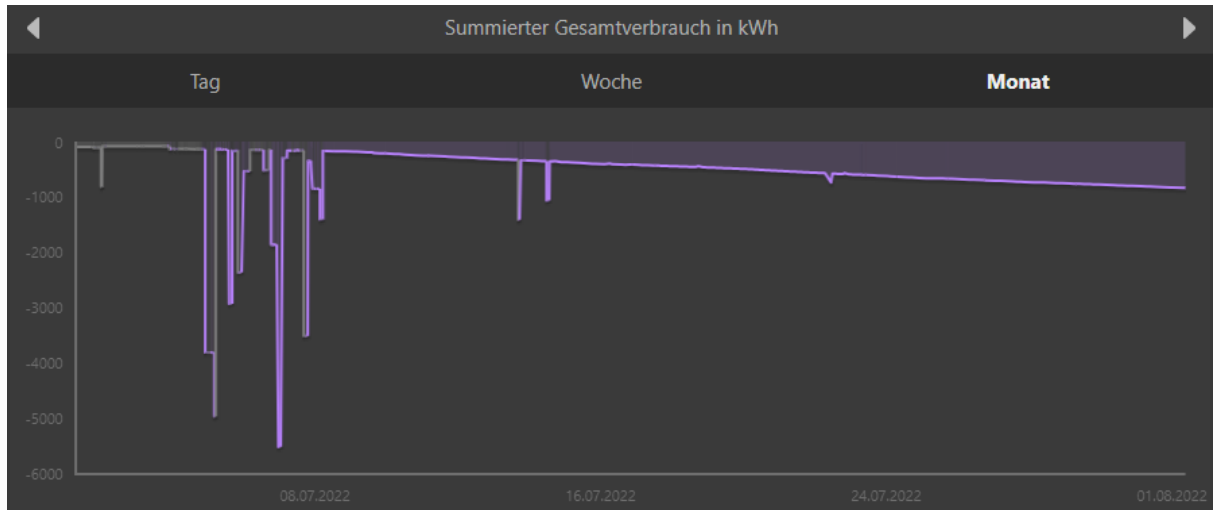

5.1.17.1 Result

The measured values are from the web-interface accessible. The measurement data are accessible, but there are data failures. The energy consumption is constantly negative, big data leaks (grey) and misinterpretations of the measurement data (peaks) being evident. The measurement data is invalid and cannot be used for further processing or calculations.

5.1.18 Test Homee 0005510E7372 "Grabenbauer" energy / week



5.1.18.1 Result

The measured values are from the web-interface accessible. The measurement data are accessible, but there are data failures. Also here are data leaks (grey) present and misinterpretations of the measurement data (peaks) being evident. The measurement data is invalid and cannot be used for further processing or calculations.

5.1.19 Test Homee 0005510E7372 "Seitinger" energy

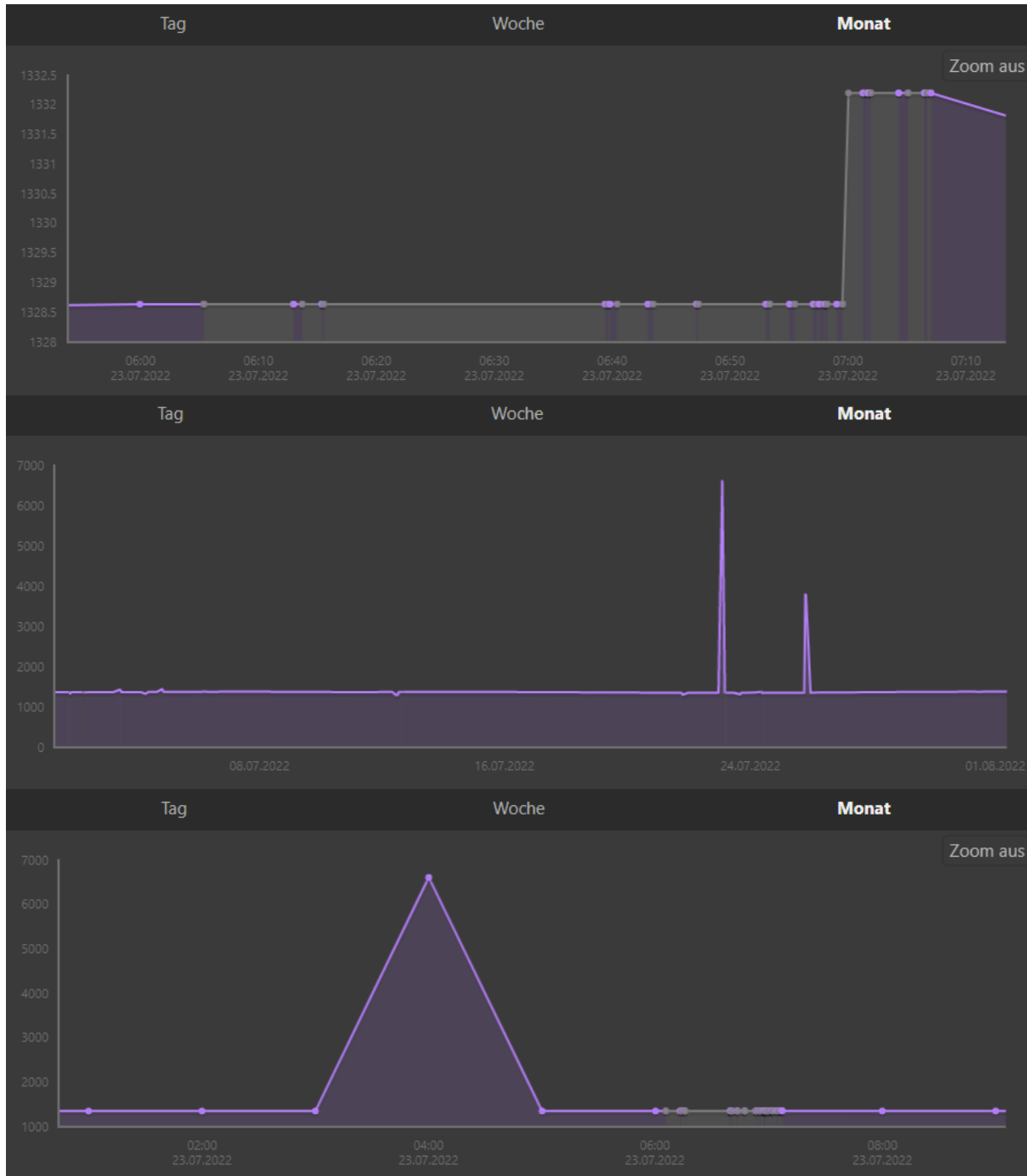

5.1.19.1 Result

The measured values are from the web-interface accessible.

There are big data leaks (grey) and misinterpretations of the measurement data (peaks) being evident. The measurement data is invalid and cannot be used for further processing or calculations.

5.1.20 Final result

The test results clearly show that measurement data measured by smart home devices such as Homee cannot deliver the required quality. Due to strong measurement errors, data gaps and connection problems, the data quality is so poor that it cannot be used for calculations.

Furthermore, a connection via the customer's modem is not stable enough to continuously deliver data and measurements. In most cases, the modem cannot be reached or can only be reached with difficulty due to the distance. The result is, that the smart home device loses the connection. Another problem is the connection between the IoT smart meter in the customer's fuse box and the smart home center (Homee). Also here is the distance and the inadequate technology the main issue.

Another issue is the insufficient Smart Home or IoT device. Due to measurement inaccuracies, connection errors and incorrect interpretation, there is a severe loss of quality. In some cases, measurement data is interpreted incorrectly, with the error rate being so high that calculations using this data are impossible.

It is not possible to filter these data errors, since too many variables would have to be considered.

A very high data quality can only be achieved by replacing the measuring devices with the PAC2200 and the direct (wired) connection to the gateway. By evaluating the data from the PAC2200 measuring devices, no misinterpretations or measurement errors occurred.

5.1.21 SIEMENS to AIT REST Interface

There is a simple RestAPI for the AIT Interface. Every site has a separate Webserver and a Client to transmit the data. In use are the http(s) protocol requests get and post.

The path of the http URL specifies the type of data. In the body is the data a json format included. In some cases, parameters are necessary.

5.1.21.1 AIT Server / Siemens Client

To send setpoints to the devices in the field over the Siemens gateway. The calculated setpoints from the AIT Server are transmitted to the gateway. The Siemens-gateway transform this data and forward the settings to the right device. The json-data include an array of device-objects. A device-object include the "*device*", "*name*", "*type*" and "*unit*" as string and the value as a numeric format.

5.1.21.2 Siemens Server / AIT Client

POST measurements

Send new measurements obtained in the field to the platform. All measurements data are collected from the Siemens-gateway, converted to a json format and forwarded to the AIT server. The json-data include an array with all collected devices and its measurements.

A device can hold multiple measurements, these are in the array "*measurements*". "*name*", "*type*" and "*unit*" are string formats, and the value is defined as a numeric format.

5.1.21.3 GET user_id

Get data for the visualization in the Siemens web interface for a certain time range. Two possibilities exist how data is exchanged:

1. Regularly the AIT platform sends the newest data to the Siemens REST server
2. Siemens requests data on demand, for instance, when a user opens its dashboard

5.1.21.4 POST configurations

Send configurations performed in the Siemens web interface to the platform. Users can set configuration parameters in the web interface which should be forwarded to the platform.

5.1.22 Firebase API (base for user interface)

To attach to a firebase database some main parameters are necessary:

- firebase projectID
- firebase api_key
- firebase realtime_database_name

The ID can be found in the firebase options and the api_key can be generated online. After that, the firebase REST API can be used.

The measurements and the data points for the diagrams are uploaded every 15 minutes. This is a generic automated process. The REST-API use

- GET
- POST
- DELETE
- PATCH
- PUT

http requests and json-objects for managing the database. To become access to the database and to manage files, these following REST commands are used.

5.1.23 Firebase integration test

This short document will cover the most important testcases regarding the integration of the firebase service in to the SIAPP-Core application.

5.1.24 Invalid login credential:

In cases that the login with the firebase project fails at start up, the firebase service will be disabled for the entire runtime, duration. To fix this issue the login credentials have to be correctly edited in the siapp_uconfig.json and the SIAPP-Core has to be restarted for the changes to take effect.

```

2022-09-27 15:46:14 | /firebase.cpp | operator() | 130 | Error - HTTP error response: {"error":{"code":"400","
errors":[{"domain":"global","message":"INVALID_PASSWORD","reason":"invalid"}], "message":"INVALID_PASSWORD"}}
2022-09-27 15:46:14 | /firebase.cpp | operator() | 131 | Error - HTTP error code: 400
2022-09-27 15:46:14 | /firebase.cpp | login_with_email | 381 | Debug - Error while signing in credentials are null

2022-09-27 15:46:14 | /siapp_core.cpp | firebase_setup | 2408 | Error - Could not log into firebase
2022-09-27 15:46:14 | /siapp_core.cpp | firebase_setup | 2409 | Error - Disabling Firebase

```

The figure above shows the error message in cases invalid credentials have been edited.

5.1.25 Network traffic:

The next test was to check whether the up- and download is within an acceptable range. This is important when analyzing whether the CLUE-Firebase network can be sustained with the free spark plan. For more information regarding the spark plan, please visit: <https://firebase.google.com/pricing?authuser=0&hl=de>

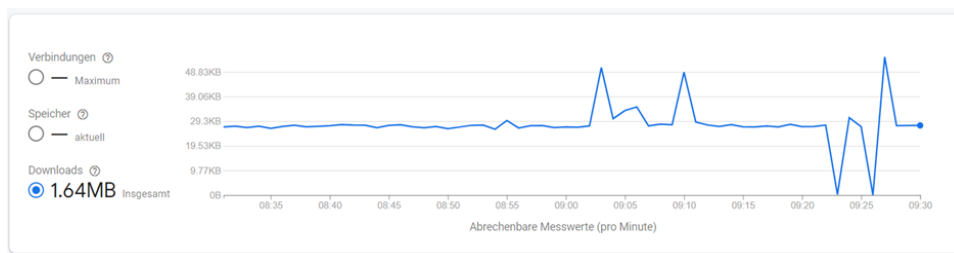

With the continuous mode enabled an average traffic of 1,6MB per hour occurs. This would amount up to 38,4MB per day and 1190MB per month. This is well within the range of the free-to-use spark plan.

5.1.26 Firebase config upload / download:

During the integration of the firebase service the configuration files were adapted. The config file siapp_uconfig.json has a section named firebase added. Another file named signal_uconfig.json was added which contains information regarding MQTT-Topics where these signals should be saved.

The files mqtt_ulist.json, siapp_config.json and signal_uconfig.json can be uploaded and also downloaded from a firestore database. The location of this config document is {community of the device}/{device-name}.

Both community name and device name are configured in the local siapp_uconfig.json file.

5.1.26.1 Uploading

The uploading of the configuration file to the firestore can be invoked via the REST-API of SIAPP-Core. A simple http request was sent to the SIAPP-Core which sent a rest request to the firebase with the contents of the config file to be saved remotely.

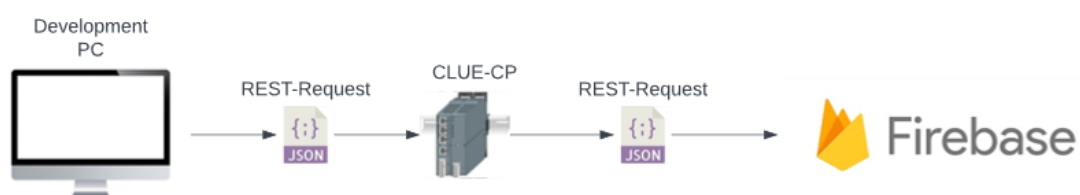

+ Feld hinzufügen

- ▼ config
 - ▶ database: {continuous: false, insert...}
 - ▶ firebase: {apiKey: "AlzaSyBJo3R29JEU..."}
 - ▶ http: {enable: true, httpHost: "...}
 - ▶ influxdb: {enable: false, influxdbHo...}
 - ▶ log: {logfile: true, loglevel: ...}
 - ▶ miscellaneous: {subscribe-all: false}
 - ▶ mqtt: {mqttHost: "127.0.0.1", mq...}
 - ▶ sweb: {swebHost: "http://172.16...}
- ▶ meta: {device: "Device-name", sl...}
- ▼ publishMQTT
 - ▶ signals: {KEBA1/#: {save_archive: t...}
 - ▶ subscribeMQTT: [{qos: 1, topic: "KEBA1/#"...}

After the invocation of the upload command the current configuration will be read from the filesystem and uploaded to the firestore. This does not necessarily have to be the configuration currently used by the SIAPP-Core, because the SIAPP-Core does not yet support live settings.

5.1.26.2 Downloading

The downloading of the configuration files is also rather straight forward. Just like with the uploading, a single command was sent to the REST-API of SIAPP-Core which the configuration, validates it and stores it locally on the machine in the folder /persist_data/admin/configuration.

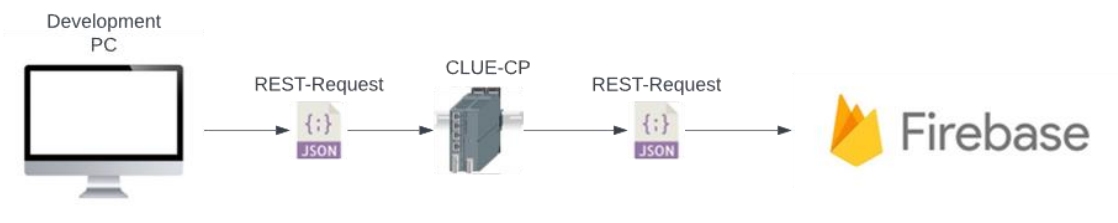

```
root@runc:/persist_data/admin/configuration# rm mqtt_ulist.json siapp_uconfig.json signal_uconfig.json
root@runc:/persist_data/admin/configuration# ls
total 8.0K
drwxr-xr-x 2 root root 4.0K Sep 27 06:52 ./
drwxr-xr-x 3 root root 4.0K Apr 22 12:57 ../
root@runc:/persist_data/admin/configuration# ls
total 20K
drwxr-xr-x 2 root root 4.0K Sep 27 06:52 ./
drwxr-xr-x 3 root root 4.0K Apr 22 12:57 ../
-rw-r--r-- 1 root root 342 Sep 27 06:52 mqtt_ulist.json
-rw-r--r-- 1 root root 894 Sep 27 06:52 siapp_uconfig.json
-rw-r--r-- 1 root root 1.1K Sep 27 06:52 signal_uconfig.json
root@runc:/persist_data/admin/configuration#
```

In the previous figure, it is visible that the configuration files can be downloaded and stored on the machine.

5.1.26.3 Firebase parsing local config file:

The entire settings regarding the firebase service reside in the siapp_config.json file. This file is parsed at the start-up of the SIAPP-Core. Due to the proven functionality of the previous test-case of uploading and downloading the success of this test-case can also be guaranteed.

```
core/out/build/MSL-GCC-Debug/siapp_core/admin/configuration/signal_uconfig.json
siapp_uconfig.json:
{"config":{"database":{"continuous":false,"insert_interval":60,"path":"/persist_data/archive/","size":10080},"firebase":{"apiKey":"AIzaSy8jWdz06kcam-xM5TiwtdZ
itQDFakzq9I","archive_path":"archives","community":"STEPHAN","dashboard_path":"dashboards","email":"siapp@siemens.com","enable":true,"enableBatching":true,"pas
sword":"12341234","projectName":"siapp-17ab1","realtimeDBname":"siapp-17ab1-default-rtdb.europe-west1.firebaseiodatabase.app"},"http":{"enable":false,"httpHost":
"","httpPort":8088,"httpsPort":4443},"influxdb":{"enable":false,"influxdbHost":"","influxdbPort":8086},"log":{"logfile":true,"loglevel":6,"mqttlog":false,"mqtt
loglevel":4,"stderr":true,"syslog":false},"miscellaneous":{"subscribe-all":false},"mqtt":{"mqttHost":"127.0.0.1","mqttPort":1883},"sweb":{"swebHost":"http://17
2.16.1.1"},"meta":{"device":"CP","siapp":{"container":"SIAPP-name","slot":0}}}
signal_uconfig.json:
{"signals":{"CP":{"save_archive":true,"save_firebase":true,"save_influxdb":true,"ui_name":"Temperatur"},"CP/test":{"save_archive":true,"save_firebase":true,"sa
```

The figure above is a debug output of the siapp_core being run. The loading of the config is successful, and all the appropriate values are written to the right variables.

5.1.26.4 Insert new value into realtime-db:

The core concept of the firebase integration is to push new received MQTT-Messages onto the realtime database. There are 2 general modes which can be selected.

1. Batched – Only the most recent MQTT-Message per topic will be pushed onto the database.
2. Continuous – All MQTT--Mmessages will be pushed onto the database.

```
2022-09-27 10:06:20 | /siapp_core.cpp | mqtt_msg_callback | 1583 |
Trace - MQTT Message: [TPAC2/TPAC2_T0_ReactivePower/var] {"timestamp":166427318
0145,"dataType":"Float","value":-13073.416992,"state":[],"meta":{"name":"TPAC2/T
PAC2_T0_ReactivePower/var","unit":""}}
```

In the figure above is a debug lo of the siapp_core depicted.

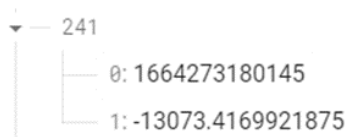

This is the entry of this specific MQTT-Message and therefore the firebase module can add this entry to the database successfully.

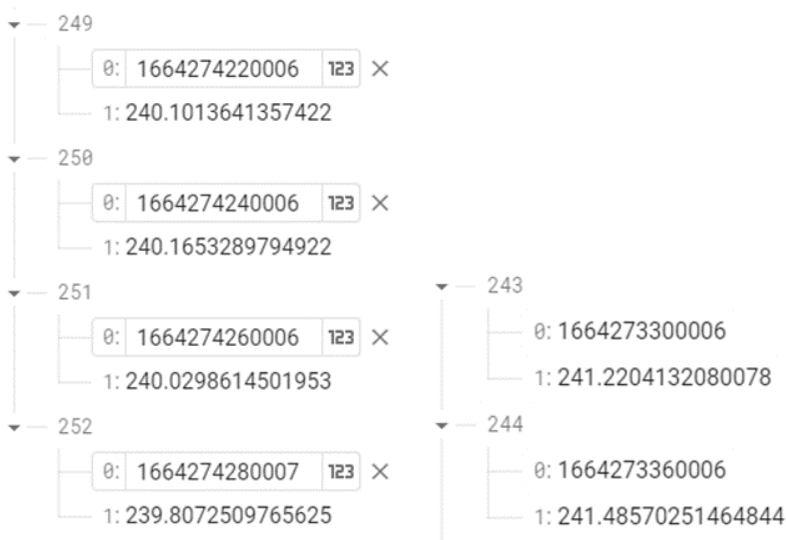

The figure on the left side are messages inserted in continuous mode. If the UNIX timestamps are converted into a human readable format, all these timestamps would have 20sec in between them.

The entries on the right on the other hand were inserted in batched mode. In this mode only adds the most recent value. The insert operation is executed every 60s roughly.

5.1.26.5 Syncing index counter realtime database:

The current system how the realtime database is being utilized by the SIAPP-Core makes it necessary for the SIAPP-Core to fetch, so called, index counter from the realtime database for every MQTT-Topic. This index counter is needed to give every [timestamp - value] - pair a way to sort and uniquely identify them within the same MQTT-Topic.

When the SIAPP-Core wants to insert a new value for the first time since start-up, it will fetch these index counter. If no index counter could be found for a signal to be inserted, 0 will be assumed and stored in the realtime database. After each insertion of a new value, the counter gets incremented by 1.

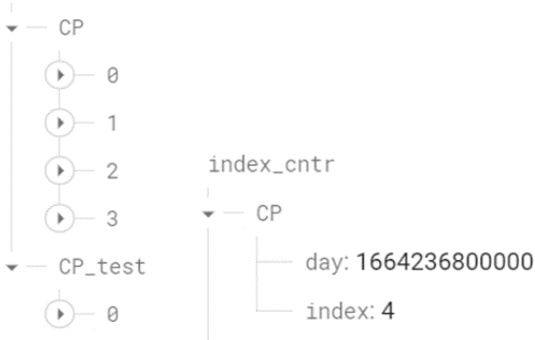

In the figure above is the section, on the left side, with the array of [key - value] - pairs and on the right side the index counter corresponding to the MQTT-topic.

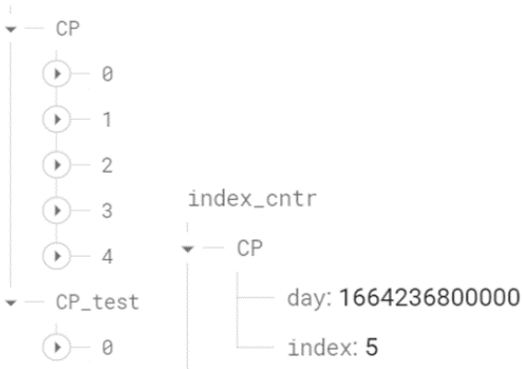

After the insertion of the new value the value CP/4 the index counter is also incremented. It is important to note, that the index counter always stores the index for the next entry. A local version of this index counter is also cached locally.

5.1.26.6 Signal config:

The signal configuration is a file both stored locally and in the remote firestore config of the SIAPP-Core. The signal configuration contains information regarding how and where MQTT-Messages received should be stored.

Every MQTT-Topic which being subscribed to should at least have a configuration for this exact signal or a configuration on a higher layer.

E.g.

Signal: [KOSTAD1PAC/KOSTAD1PAC_L1_Voltage/V](#)

Configuration on a higher layer: [KOSTAD1PAC/KOSTAD1PAC_L1_Voltage/#](#) ; KOSTAD1PAC/#

If not even none of the above are present a default configuration will be assumed, and a warning will be logged.



```
TPAC2/TPAC2_L3_Current/A
├── data
│   ├── 0: 1664274280066
│   └── 1: 115.29046630859375
└── meta
    ├── name: "Test"
    └── unit: ""
```

```
"TPAC2/#": {
  "save_archive": true,
  "save_firestore": true,
  "save_influxdb": false,
  "ui_name": ""
},
"TPAC2/TPAC2_L3_Current/A": {
  "save_archive": true,
  "save_firestore": true,
  "save_influxdb": false,
  "ui_name": "Test"
},
```

In the figure above is depicted the dashboard entry of the mqtt-topic TPAC2/TPAC2_L3_Current/A. In the meta under the name "name" is the value Test. This is the name which can be used by applications or websites to display the signal. This value is configured in the signal_uconfig.json file.

To test whether, a specific signal could also be excluded from being saved in the firebase or archive a local version of the SIAPP-Core was run in a WSL container.

```
2022-09-27 13:49:23 | /siapp_archive.cpp | archive_periodic_insert_1 | 455 | Info - MQTT-Message
with topic CP/test will not be stored in the firebase. Disabled in the signal_uconfig.json
```

```
1  {
2  "signals": {
3    "CP": {
4      "ui_name": "Temperatur",
5      "save_firestore": true,
6      "save_archive": true,
7      "save_influxdb": true
8    },
9    "CP/test": {
10     "ui_name": "Voltage",
11     "save_firestore": false,
12     "save_archive": true,
13     "save_influxdb": true
14   }
15 }
16 }
```

This also proves that via the signal_uconfig.json it is possible to selectively store specific signals in the firebase and others not.

5.1.27 CLUE User Interface

The web site for the CLUE user interface is hosted on a siemens server in an internet DMZ, where a customer can access with a standard browser like Google Chrome via following domain:

<https://a8000.siemens.com>

The web site is written in REACT and is using libraries like MATERIAL-UI, FIREBASE, APEXCHARTS, REDUXJS/TOOLKIT, TAILWINDCSS, etc.

Landing / Login / Registration

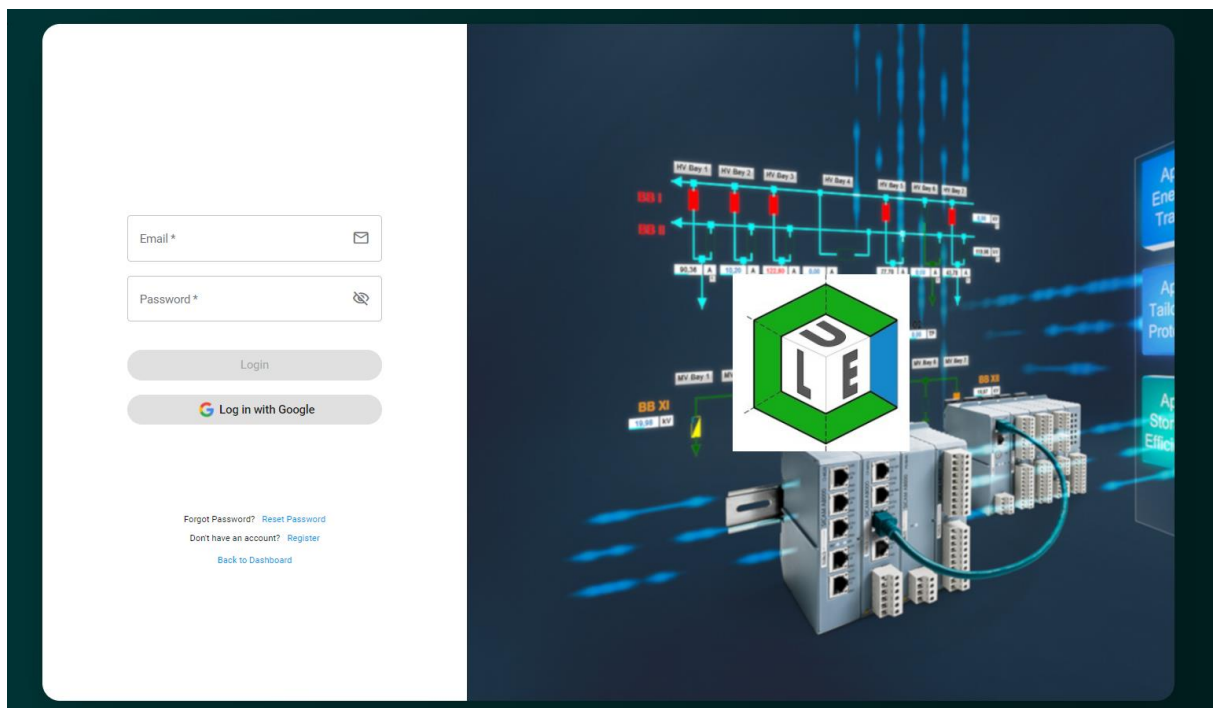

User registration and authentication are used for data privacy. We support email and password authentication as well as Google login. To verify the email-address a verification email will be send for email/password registration. A reset of password is possible via email if the user forgot his password.

5.1.28 Dashboards



The PROJECT dashboard is shown after login. This dashboard is used to show some user specific data if devices are installed, and the user is a member of the community.

Additionally, a COMMUNITY dashboard is available to show some data of the community. Due to privacy reasons, there is no information about single user, only overall results are displayed.

The ADMIN dashboard is only visible for project admins. Some additional info can be displayed.

Four different types of widgets are integrated:

- **Simple Card** (only a current value)
- **Card with Graph** (current value and a small graph)
- Graph
- Bar Graph

The data will be synchronized every 15 minutes via Firebase from/to SICAM A8000 SIAPP.

5.1.29 Settings

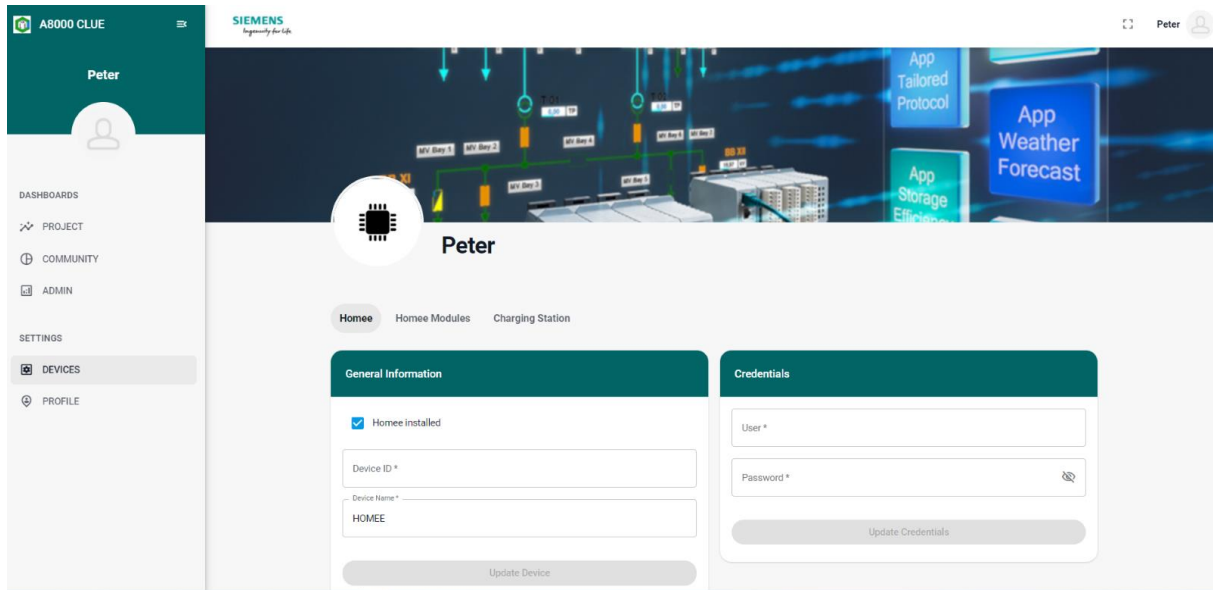

With device settings the SICAM A8000 can connect, monitor and control specific parts of the home automation and map data for/from AIT platform. Following device settings are available:

- HOMEe (ID, NAME)
- HOMEe Credentials (User, Password)
- HOMEe Modules (Aeotec 3ph Meter, FIBARO Double Switch)
- Charging Station (IP)

Some user profiles are necessary to map data to correct geographical point. Following settings for profile are available:

- First and Last Name
- Address
- Post Code and City
- Country
- Change Email and Password

5.1.30 Google Firebase

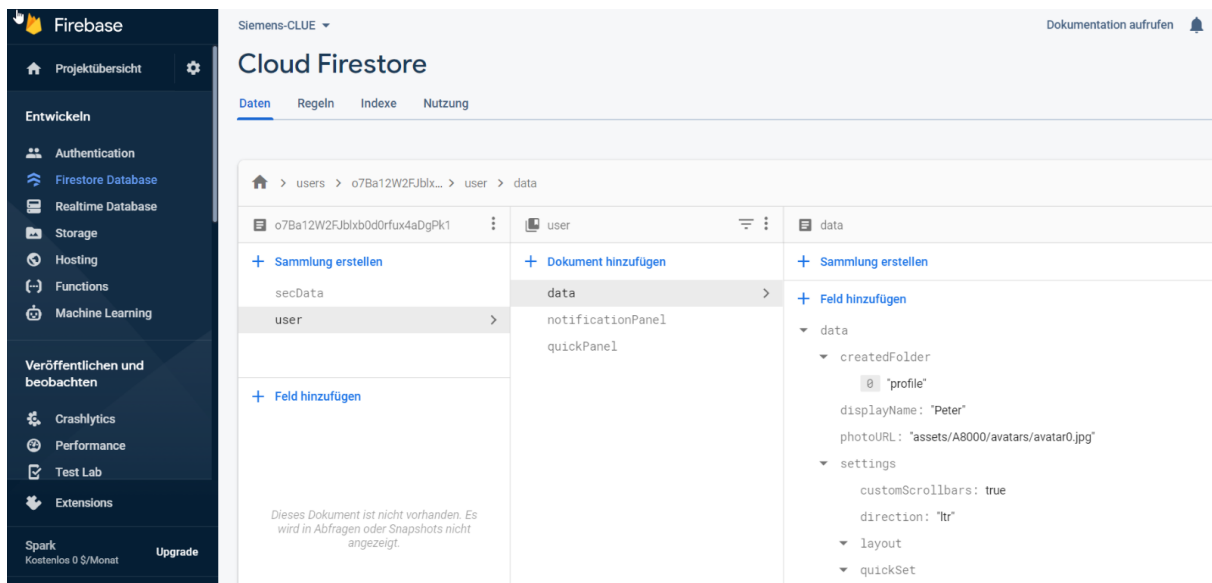

Google Firebase is used as database for the web frontend. So, it is possible to have separate access from user and SICAM A8000. A webserver would be also possible on SICAM A8000, but therefore a port must be open and so there would be a security leak. On the other hand, the concept could be scaled for more than 100 users and so it is too much for an embedded system. Google Firebase is free for some smaller application like the field test. For a product another database has to be used (e.g. separate backend server) or an upgrade is necessary.

Firebase has already integrated some useful features:

- Different authentication services (Email/PW, Google Login, etc.)
- Security rules for data access (also for specific parts)
- Different storages (Firestore, Realtime Database, File Storage)
- Options for data privacy
- Analytics

5.1.31 AIT Rapid Deployment Platform

An important part of the demonstrator in Gasen is the AIT Rapid Deployment Platform (RDP). Its task is the scheduling of the flexibilities in the energy community while guaranteeing a save operation of the power gird. The architecture of the platform is shown in Figure 56. It consists of modular building blocks which communicate with each other via the in-memory database Redis. Furthermore, the time-series database TimescaleDB is used for storing persistent data. The RDP communicates over a gateway which is provided by Siemens with the devices in the community. The gateway sends the measurements periodically every minute to a REST-endpoint which is provided by the RDP.

The main component of the RDP is the Grid Capacity Management (GCM). The GCM optimizes the operation of the flexibilities while considering the voltage limits in the grid and the thermal limits of the lines and transformers. It yields setpoints for the storages and limits for the electric vehicle charging stations. These setpoints and limits are sent to a REST-endpoint from the gateway of Siemens. This gateway routes the signals further to the devices in the energy community.

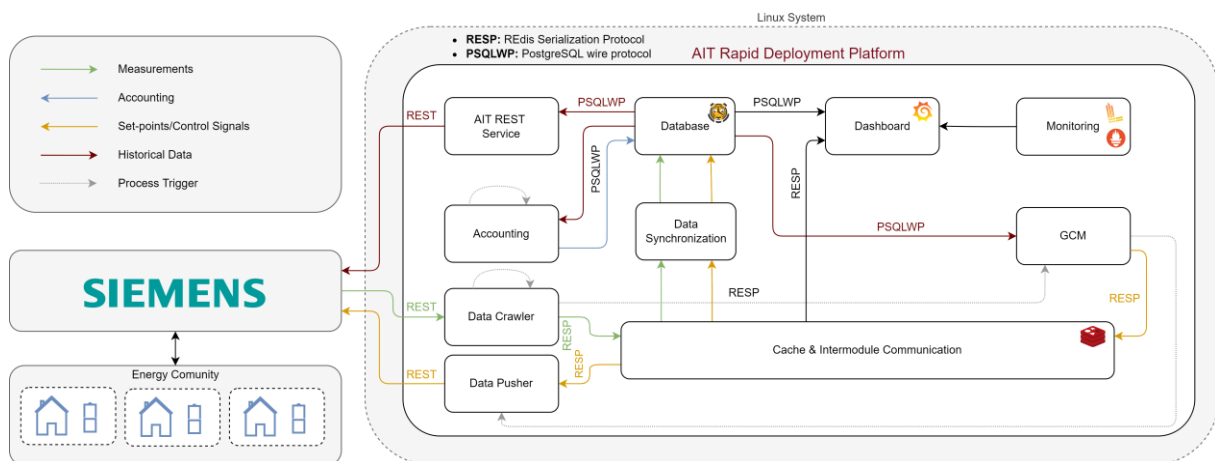

Figure 56: Architecture of the AIT Rapid Deployment Platform which is deployed in the demo region Gasen

All components of the RDP are containerized and are deployed with Docker. In such a container the application together with its dependencies and the environment is bundled. Dockers takes also care about restricting access to the containers for security and restarts containers in case of an error. The RDP uses Portainer for managing the Docker containers. Figure 57 shows the dashboard of Portainer which is deployed as a module of the RDP. The dashboard lists the Docker containers and their status. It allows also the inspection of the containers and their manual restart.

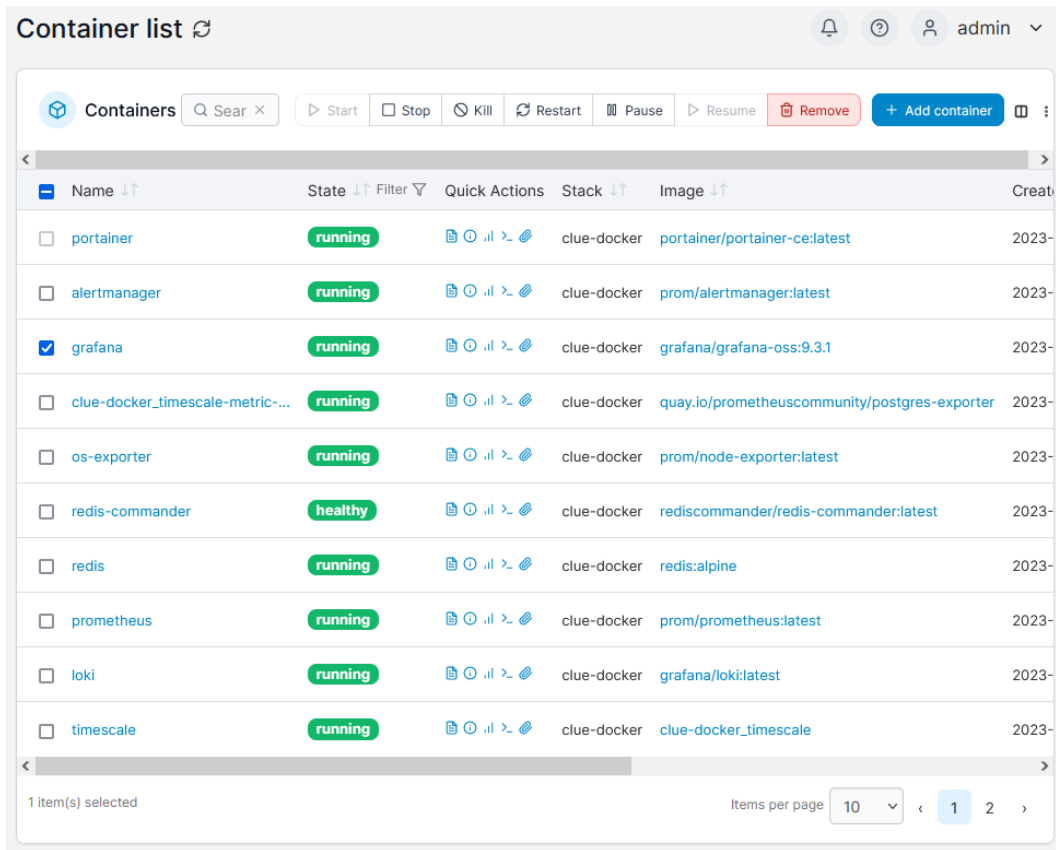

Figure 57: Portainer is used for managing the Docker containers of the AIT Rapid Deployment Platform

Prometheus is used by the RDP for monitoring the status of the containers. Grafana visualizes the metrics obtained by Prometheus. Figure 58 shows the dashboard of RDP's database. This helps in monitoring the current status of, for example, the index sizes of the tables and the rows written to the database per second.



Figure 58: Dashboard of the database

Figure 59 shows metrics of the machine on which the RDP is running. With the metrics of the host machine, resource problems can be identified in advance, for instance, when the hard disc is starting to get full.



Figure 59: Dashboard of the machine which runs the AIT Rapid Deployment Platform

Besides the dashboards in Grafana which visualize the metrics obtained by Prometheus, the platform can automatically send alerts to inform the user about detected problems. It can use different channels like email, MS-Teams, and Slack. In Figure 60 an alert is shown which was end to Slack. It informs about problems in the processing of received data. Afterwards, it informs also that the problem was solved, and the incoming data can be processed again.

19. Dezember 2022

RDP AlertManager APP 14:24 Uhr

[FIRING:1] UnprocessablePayload for CLUE_datacrawler
 (alertname="UnprocessablePayload", handler="/measurements", instance="data_crawler:1515", job="CLUE_datacrawler", method="POST", severity="warn", status="4xx")
 Alert: Unprocessable Payload - warn
 Description: data_crawler:1515 of job CLUE_datacrawler has received and unprocessable measurements payload.
 Details:
 • alertname: UnprocessablePayload
 • handler: /measurements
 Mehr anzeigen

[RESOLVED] UnprocessablePayload for CLUE_datacrawler
 (alertname="UnprocessablePayload", handler="/measurements", instance="data_crawler:1515", job="CLUE_datacrawler", method="POST", severity="warn", status="4xx")
 Alert: Unprocessable Payload - warn
 Description: data_crawler:1515 of job CLUE_datacrawler has received and unprocessable measurements payload.
 Details:
 • alertname: UnprocessablePayload
 • handler: /measurements
 Mehr anzeigen

Figure 60: The rapid deployment platform sends an alert to inform about a problem in the received data

Additionally, to the metrics collected with Prometheus, the AIT RDP leverages Loki for gathering logs from all containers. These help in addition to the metrics in understanding the cause of problems. For instance, when a user receives an alert over Slack, he/she can search to logs to find the root cause(s) which led to the problem.

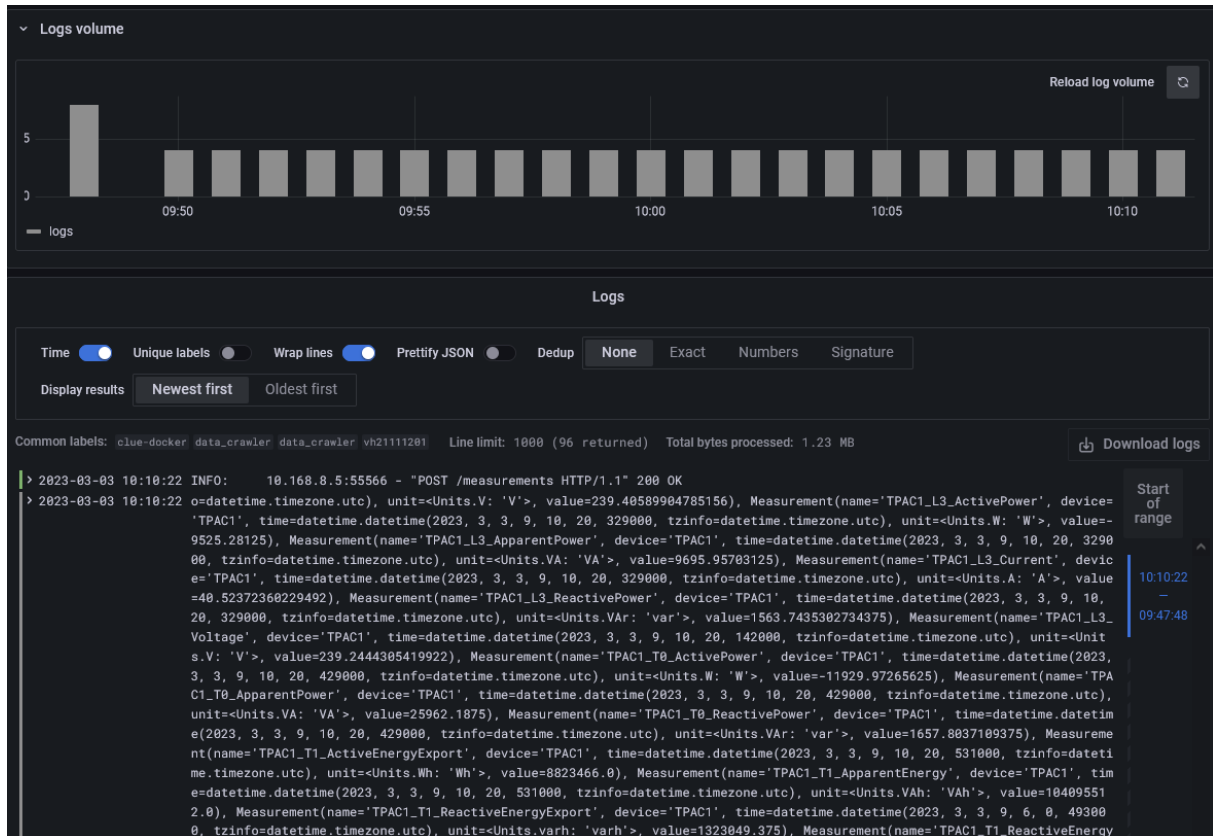

Figure 61: Logs gathered in the AIT rapid deployment platform with Loki

During the demonstration phase multiple tests were performed to test the correct functioning of all parts of the systems in the demo region Gasen. Figure 62 shows the data which was logged during a test of the xelectrix battery which was installed in Gasen in the scope of the project. On the top right is the charging/discharging current setpoint of the battery. The setpoint of the active power was changed multiple times and it can be seen that the current changes accordingly. At the bottom middle are the measurements of the current for each phase which change also accordingly to the setpoint. Due to the voltage variations the current varies to since the setpoint was an active power setpoint. This can be seen in the bottom right plot where the active power is displayed in green.



Figure 62: Measurements at the xelectrix battery during a test

Most important are good measurements of the GCM so that it can correctly identify the current state of the grid and then makes adequately schedules the operation of the flexibilities. Figure 63 shows the dashboard of the measurements of a customer which is part of the energy community in the demo region Gasen. The data is measured with PAC devices from Siemens which transmit periodically voltage, current, and power measurements to the AIT RDP.



Figure 63: Measurements of a customer of the energy community

The AIT RDP exposes a REST-interface for receiving measurements and for providing information about the energy community. With OpenAPI all endpoints and the format of the data which is expected to be exchanged is specified. Furthermore, the REST-server performs automatic validation of incoming data. If the format of an incoming request does not comply with the schema, the request will be rejected, and the sender receives information with details why the request was not accepted. Figure 64 shows a web frontend (Swagger UI) for the exposed endpoints. With this frontend it is also possible to test the interface directly from the web browser.

CLUE REST Server AIT 0.1.0 OAS3

/openapi.json

REST server for the AIT Rapid Deployment Platform in the project CLUE

Authorize

default		^
POST	/measurements Measurements	⌵ 🔒
GET	/data/energy/total_energy_production/{year} Get Total Energy Production	⌵ 🔒
GET	/data/energy/current_energy_production/ Get Current Energy Production	⌵ 🔒
GET	/data/battery/soc Get Battery Soc	⌵ 🔒
GET	/data/accounting/annual_energy_savings/{year} Get Annual Energy Savings	⌵ 🔒
GET	/data/grid/current_state/ Get Current Grid State	⌵ 🔒

Figure 64: REST endpoints of the AIT RDP

5.1.32 1.New AIT connectivity:

Only minor changes were made to the AIT connectivity. From now on will no communication with the home devices happen. Also, a minor mistake, regarding which values should be transmitted to the AIT. By mistake old, cached values were also transmitted.

```

2022-09-27 12:41:00 | /AIT_REST.cpp | AIT_Post_Data_Request | 280 | Info - POST to AIT-REST API (10.137.0.30)
2022-09-27 12:41:00 | /AIT_REST.cpp | AIT_Post_Data_Request | 299 | Trace - AIT Data: {"data":[{"device":"TPAC2","name":"TPAC2_L
receive_time":1664282460000,"time":1664282440095,"type":"Float","unit":"W","value":-28600.375},{"device":"TPAC2","name":"TPAC2_L3_ActivePower"
664282460000,"time":1664282440095,"type":"Float","unit":"W","value":-18220.58390625},{"device":"TPAC1","name":"TPAC1_L3_Voltage","receive_tim
time":1664282460031,"type":"Float","unit":"V","value":239.49853515625},{"device":"TPAC2","name":"TPAC2_T1_ReactiveEnergyImport","receive_tim
time":1664282400161,"type":"Float","unit":"varh","value":15179764},{"device":"TPAC2","name":"TPAC2_L2_Current","receive_time":1664282460000,
095,"type":"Float","unit":"A","value":93.09893798828125},{"device":"TPAC1","name":"TPAC1_L1_Current","receive_time":1664282460000,"time":1664
"Float","unit":"A","value":16.30033115722656},{"device":"KOSTAD1PAC","name
2022-09-27 12:41:00 | /AIT_REST.cpp | operator() | 315 | Info - AIT POST successful: status code: 200 - OK
  
```

In the figure above is depicted the debug log output of the SIAPP-Core. All necessary values are transmitted to the AIT without any issues.

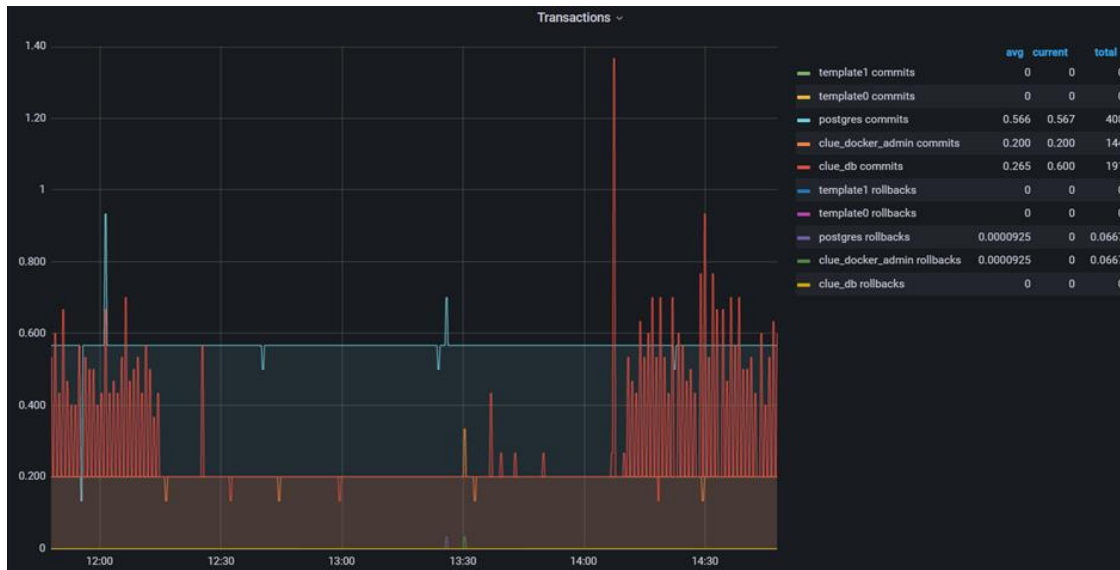

The Grafana database also displays that commits from the clue network were received and stored.

5.1.33 Machine learnt distribution system state estimation

The GCM requires accurate state information in each time step. Since the distribution system suffers from low observability means were investigated to obtain state information from partial measurements only. Machine learning models were employed to forecast the system state. This forecaster works tightly together with the GCM. It receives measurement data from the meters in the demonstrator and predicts quantities that are not observed in the grid but required for grid capacity management. The predictions of the forecaster are forwarded to the GCM.

The forecaster employs a fast machine learning model that was trained for predicting measurement quantities within a certain grid topology. Specifically, artificial neural networks (ANN) and linear regression (LR) models were used and compared to each other performance-wise. The sole input required for the model training is the grid topology, so that lack of training data is not an issue. Data can be produced with a suitable power flow solver. Six different test grids and the real one from the Gasen demonstrator were investigated and accuracy of prediction in various scenarios of known and unknown positions in the grid were examined, to establish the feasibility of this new topology-based method for distribution system state estimation.

The development of the forecaster focused on a realistic setting with very low observability in the grid. It was shown that the root mean square error (RMSE) of unobserved voltages was below 0.01 p.u. and around 0.0025 p.u. if at least 25% of the busbars were observed - for a sample grid (grid 06 – see figure below) with ten loads of active powers up to 10 kW and reactive powers up to 5kVAr. As a complementary metric the R^2 score was used which gives an indication of the goodness of a fit, with an upper bound value of one. An exponentially decaying error with increasing fraction of observed quantities was encountered, which alleviates the low-observability problem tremendously and allows accurate predictions of the forecaster even under such conditions. Both algorithms, the ANN and LR models performed equally well.

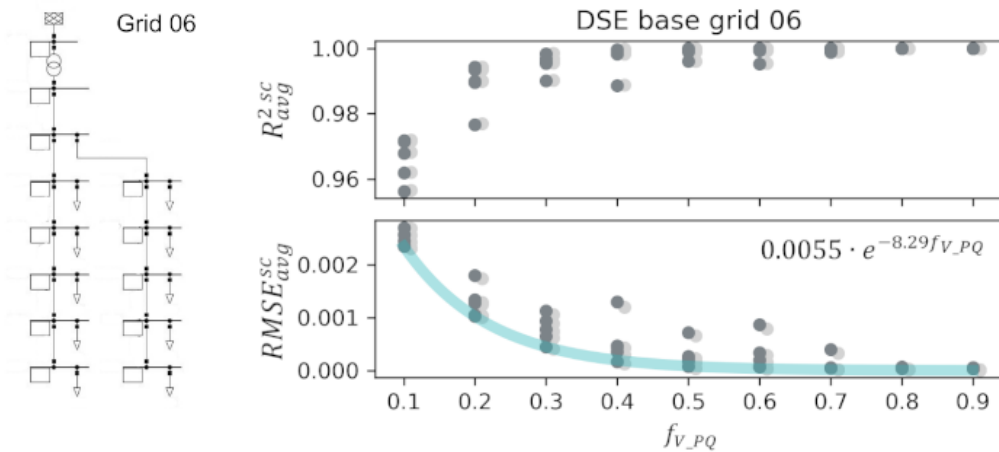

Figure 65: Left - the grid topology of the investigated test grid 06. Right - The two employed metrics for different fractions of observed locations in the grid in terms of voltages at busbars together with the corresponding loads ($f_{V,PQ}$), averaged over all predicted quantities (avg). Each dot per fraction indicates the average over a different scenario of measurement positions. Dark grey relates to the performance of the ANN model while light grey (slightly shifted to the right for better visibility) originates from the LR.

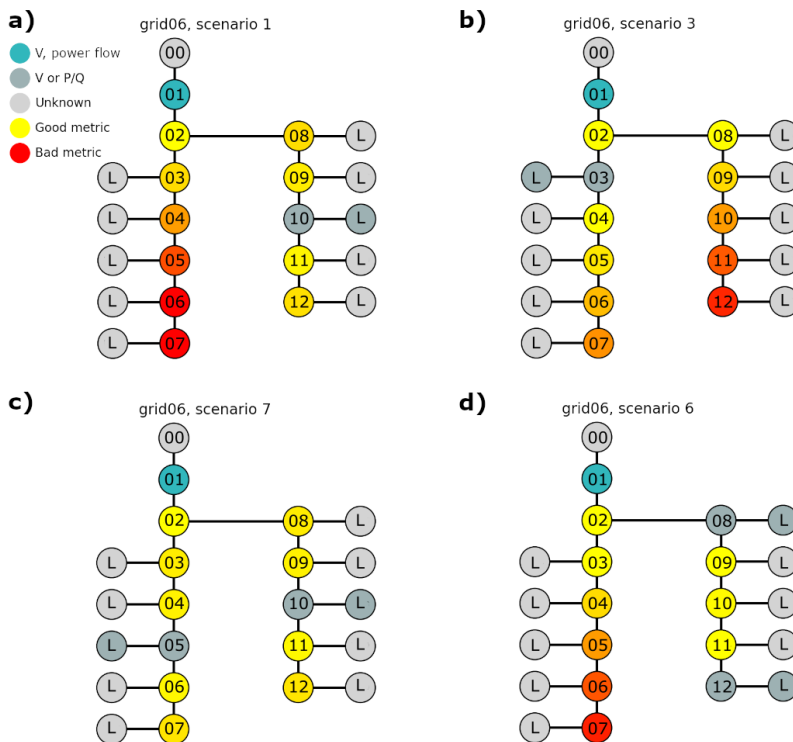

Figure 66: Example scenarios of measurement device placement and predictability for the test grid 06. Colour indicates if a position was observed (green, dark grey), or not (light grey), or how good the prediction R^2 score was (with a lower bound cut-off value of 0.9 in this case labelled as 'bad metric').

A demonstrator for optimal grid capacity management was set up in the municipality of Gasen in Austria. The grid information of the village was made available to the project so that machine learnt state estimation could be investigated. Various scenarios of measurement device placements were analysed and compared with the actual scenario in the Gasen demonstrator. In that case the grid contained 19 metering positions with

measurement devices installed for the project. In total 148 busbars are found in the Gasen grid, which means the fraction of observed busbars f_v was about 13% only. Active and reactive powers of loads had 0-5 kW / VAR respectively, PV-Systems up to 5 kW / VAR, and two storages (battery / hydrogen) with -75 to +75 kW / VAR each were present. Although the grid was not well observed, the prediction error metrics remained quite small, in the Gasen case on average over the busbars the RMSE was about 0.001 pu.

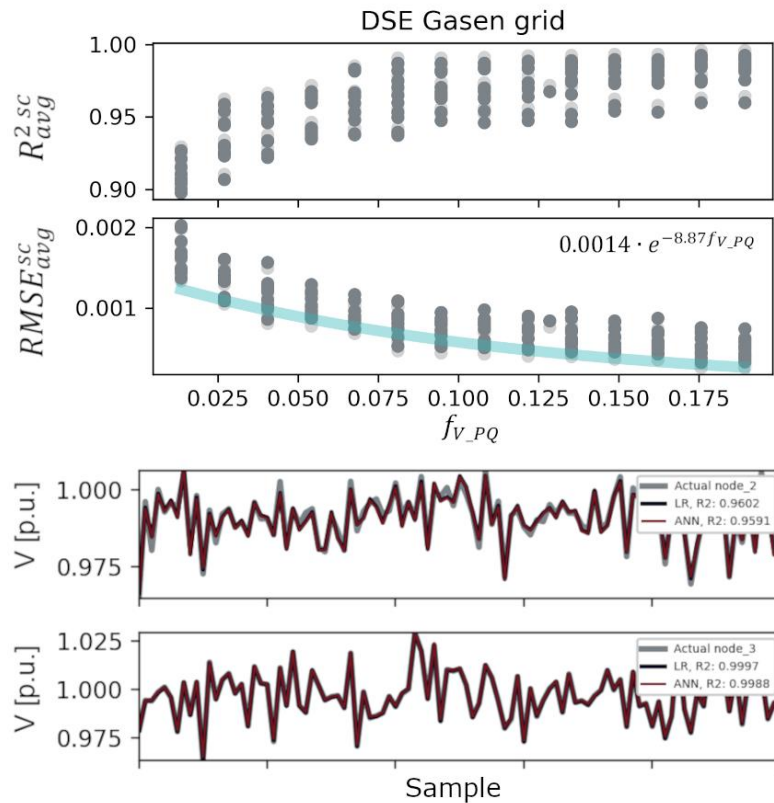

Figure 67: Upper – Prediction metrics for the Gasen grid scenarios with the actual Gasen case located at a fraction of 0.13. The measurement device positioning was not ideal as can be seen from the elevated position in the RMSE trace envelope. Lower – exemplary forecasts for unseen input data from the Gasen demonstrator case trained ML models for two busbars (node_2, node_3).

5.2 Cybersecurity and Intrusion Detection

[Intro about cybersecurity-related risks]

5.2.1 The STRIDE Threat Model

The threat analysis is based on the STRIDE approach [11] developed by Microsoft for modelling threats. To apply the STRIDE model to a system, it is necessary to analyse how the individual threats of the model affect the individual components or assets and their connection to other components. A distinction is made between 6 categories of threats.

Table 1: STRIDE-Categories

Threat	Affected property	Definition
--------	-------------------	------------

Spoofing	Authentication	Pretending to be something else or another person
Tampering	Integrity	Change data or code
Repudiation	Non-Repudiation	Pretending not to have performed an action
Information Disclosure	Confidentiality	Denial or degradation of quality of service to users
Denial of Service	Availability	Denial or degradation of quality of service to users
Elevation of Privileges	Authorization	Acquisition of rights without proper authority

To create the threat model, reference is made to the assets that play a significant role in the three use cases. A more detailed breakdown of the actors is not envisaged and is also not possible on the basis of the present level of detail of the use cases. It should also be noted that the analysis also takes into account threats that are difficult to realise through the use of the defined security measures.

5.2.2 Risk Analysis

The following table describes the different risks for the CLUE architecture outlined in Section 5.1.11. The main target of the analysis is the RDP that communicates over the Siemens gateway with devices in the energy community. The gateway sends the measurements periodically every minute to a REST-endpoint which is provided by the RDP.

Entity	Type	Source	Destination	Threats
Measurement Gateway - RDP	Flow	Gateway	RDP	S Sending measurement data on behalf of the gateway <u>Impact:</u> Send fake measurement data and pretend increased or decreased consumption. Increased: Loads should reduce their consumption. Decreased: Risk of grid overload since loads increase their consumption. <u>Likelihood:</u> High likelihood since connection between the Gateway and the RDP is not encrypted and is using password authentication. The password is sent in clear and an attacker who is on the same network could get access to it.
				T Tampering with measurement data <u>Impact:</u> Manipulate measurement data to pretend lower or higher consumption (see S above) <u>Likelihood:</u> High likelihood (see S above)
				R
				I Unauthorized access to measurement data <u>Impact:</u> Attackers gain access to measurement data, e.g. to create detailed user profiles in particular for Homees since customer personal data is affected. <u>Likelihood:</u> High since measurement data is not encrypted
				D Measurement data cannot be sent <u>Impact:</u> No data can be sent due to disruption of the communication network or faulty devices. In case the RDP receives no data it changes into emergency mode and stops sending set points. <u>Likelihood:</u> High since measurement data is transmitted over wireless networks.

				E	
Measurement Homee→Gateway	Flow	Homee	Gateway	S	Sending measurement data on behalf of the Homee <u>Impact:</u> Send fake measurement data and pretend increased or reduced consumption. Increased: Loads are potentially requested to reduce their consumption. Decreased: Risk of grid overload since loads can increase their consumption. <u>Likelihood:</u> Currently unlikely due to authentication of measurement data.
				T	Tampering with measurement data Manipulate meter reading and consumption Currently unlikely due to the signature of the metering data
				R	
				I	Unauthorized access to measurement data. Attackers gain access to the measurement data, e.g. to create detailed user profiles. Measurement data is encrypted between the meter and the central system.
				D	Measurement data cannot be sent No data can be sent due to disruption of the communication network Meter stores data and sends it when communication is available again
				E	
Measurement Substation→Gateway	Flow	Substation	Gateway	S	Sending measurement data on behalf of the substation Send fake measurement data and pretend decreased increased load (power), current, voltage ??. Currently unlikely due to authentication of measurement data.
				T	Tampering with measurement data Manipulate measurement data, see S
				R	
				I	Unauthorized access to measurement data. Attackers gain access to the measurement data

					Measurement data is encrypted between the substation and the Gateway
				D	Measurement data cannot be sent No data can be sent due to disruption of the communication network No major impact expected as long as grid is in normal condition
				E	
Measurement CP→Gateway	Flow	Charge Point	Gateway	S	Sending measurement data on behalf of the CP <u>Impact:</u> Send fake measurement data and pretend increased or decreased consumption. Since the CP can be a major load wrong measurements can have a high impact on the grid. Increased: loads should reduce their consumption. Decreased: risk of grid overload since loads increase their consumption. <u>Likelihood:</u> Currently unlikely due to authentication of measurement data.
				T	Tampering with measurement data <u>Impact:</u> Manipulate measurement data to pretend lower or higher consumption (see S above) <u>Likelihood:</u> Currently unlikely due to authentication of measurement data
				R	
				I	Unauthorized access to measurement data <u>Impact:</u> Low, since attackers are not able to identify individual CP users. <u>Likelihood:</u> Measurement data is encrypted between CP and central system
				D	Measurement data cannot be sent <u>Impact:</u> No data can be sent due to disruption of the communication network or faulty devices. Medium impact because CP loads can be high and might have an impact on grid capacity.

					<u>Likelihood:</u> High since measurement data is transmitted over Public Internet.
				E	
Measurement Battery->Gateway	Flow	Battery	Gateway	S	Sending measurement data on behalf of the Battery <u>Impact:</u> Send faked measurement data and pretend increased or decreased consumption. Since the Battery is major load wrong measurements can also have a major impact on the grid. Increased: loads should be requested reduce their consumption. Decreased: risk of grid overload since loads increase their consumption. <u>Likelihood:</u> Currently unlikely due to authentication of measurement data.
				T	Tampering with measurement data <u>Impact:</u> Manipulate measurement data to pretend lower or higher consumption (see S above) <u>Likelihood:</u> Currently unlikely due to authentication of measurement data
				R	
				I	Unauthorized access to measurement data <u>Impact:</u> Low, since attackers are not able to identify individual users. <u>Likelihood:</u> Measurement data is encrypted between CP and central system
				D	Measurement data cannot be sent <u>Impact:</u> No data can be sent due to disruption of the communication network or faulty devices. Medium impact because battery load can be high and might have an impact on grid capacity.

					<u>Likelihood:</u> High since measurement data is transmitted over Public Internet.
				E	
Set point Gateway → Battery	Flow	Battery	Battery Controller	S	Sending measurement data on behalf of the Battery <u>Impact:</u> Send faked measurement data and pretend increased or decreased consumption. Since the Battery is major load wrong measurements can also have a major impact on the grid. Increased: loads should be requested reduce their consumption. Decreased: risk of grid overload since loads increase their consumption. <u>Likelihood:</u> Currently unlikely due to authentication of measurement data.
				T	Tampering with measurement data <u>Impact:</u> Manipulate measurement data to pretend lower or higher consumption (see S above) <u>Likelihood:</u> Currently unlikely due to authentication of measurement data
				R	
				I	Unauthorized access to measurement data <u>Impact:</u> Low, since attackers are not able to identify individual users. <u>Likelihood:</u> Measurement data is encrypted between Battery and battery controller
				D	Measurement data cannot be sent <u>Impact:</u> No data can be sent due to disruption of the communication network or faulty devices. Medium impact because battery load can be high and might have an impact on grid capacity.

					<u>Likelihood:</u> High since measurement data is transmitted over Public Internet.
				E	
Set Point RDP->Gateway		RDP	Gateway	S	Sending set points on behalf of the RDP <u>Impact:</u> The gateway receives too high or too low set points for power or consumption. Too high: Risk of grid overload Too low: loads reduce their consumption (CP, battery, Homee). <u>Likelihood:</u> Low, since data is authenticated
				T	Tampering with the set points See (S) above
				R	
				I	Unauthorized access to set points <u>Impact:</u> No major impact expected since individual users cannot be identified. <u>Likelihood:</u> High since set points are not encrypted.
				D	Set points cannot be sent <u>Impact:</u> No data can be sent due to disruption of the communication network or faulty devices. Medium to high impact. Homees and charging station will continue to use the already existing set points while the battery will change to emergency mode when no data is received. <u>Likelihood:</u> High since measurement data is transmitted over Public Internet.
				E	
	Flow	Gateway	Homee	S	Sending set points on behalf of the Gateway

Set Point Gateway → Homee					<u>Impact:</u> The Homee receives to high or too low set points for power consumption. Too high: Risk of grid overload Too low: Homees reduce their consumption <u>Likelihood:</u> Low, since data is authenticated
					T Tampering with the set points See (S) above
					R
					I Unauthorized access to set points <u>Impact:</u> Depending on how e.g. individual contracts are reflected in the set points attackers might be able to derive user information from set points. <u>Likelihood:</u> Low since data is encrypted
					D Set points cannot be sent <u>Impact:</u> No data can be sent due to disruption of the communication network or faulty devices. Medium impact, Homee will continue to use the already existing set point <u>Likelihood:</u> High since measurement data is transmitted over Public Internet.
E					
Set Point Gateway → Charge Point	Flow	Battery Controller	Battery	S Sending set points on behalf of the Gateway <u>Impact:</u> The CP receives to high or too low set points for power or consumption. Too high: Risk of grid overload Too low: charging power is reduce <u>Likelihood:</u> Low, since data is authenticated	

					T	Tampering with the set points See (S) above
					R	
					I	Unauthorized access to set points <u>Impact:</u> Attacker could gather information about the battery storage. <u>Likelihood:</u> Low since set points are encrypted
					D	Set points cannot be sent <u>Impact:</u> No data can be sent due to disruption of the communication network or faulty devices. Medium impact, the Charge Point continues to use the existing set point. However, if the grid is in a condition that actions are required the Charge Point will e.g., not reduce the charging power. The behaviour of the charge point does not have a major impact on the grid since it is not a high-power charger. <u>Likelihood:</u> High since measurement data is transmitted over Public Internet.
					E	
Set Point DSO → Battery	Flow	Battery Controller	Battery		S	Sending set points on behalf of the DSO <u>Impact:</u> Send faked set points data and increase or decrease consumption. Too high: Risk of grid overload Too low: charging power is reduce <u>Likelihood:</u> Low, since data is authenticated
					T	Tampering with the set points See (S) above
					R	
					I	Unauthorized access to set points

					<u>Impact:</u> Attacker could gather information about the battery storage. <u>Likelihood:</u> Low since set points are encrypted
				D	Set points cannot be sent <u>Impact:</u> No data can be sent due to disruption of the communication network or faulty devices. Medium to high impact, the Charge Point continues to use the existing set point. However, if the grid is in a condition that actions are required the Charge Point will e.g., not reduce the charging power. The behaviour of the charge point does not have a major impact on the grid since it is not a high-power charger. <u>Likelihood:</u> High since measurement data is transmitted over Public Internet.
				E	

5.2.3 Dataset exploration and characterization

A paramount preliminary phase to the anomaly detection is the dataset exploration, which has been performed in an offline fashion taking into account the time period from the 20th of January 2022 to the 9th of March 2023.

All the analyses reported in this section were conducted using [Python 3.9.0](#). We first established a connection to the PostgreSQL database by means of the [psycopg2](#) library. The connection generates a cursor object that allows to query the database, as shown in Figure 67.

```
# Establishing the connection
conn = psycopg2.connect(database=db_name, user=user, password=pwd, host=host, port=port)
conn.autocommit = True

# Creating a cursor object
cursor = conn.cursor()
```

Figure 67: Connection to the CLUE PostgreSQL DB. The parameters *db_name*, *user*, *pwd*, *host* and *port* are the standard credentials to the database.

We then queried the DB to obtain the names of the available devices and the associated measurements and saved all the available data on a single csv file per device. We observed two different types of devices, based on the available measurements: the Homee devices - whose behaviour was described in Section 5.1.6 and is known to be anomalous, and the PAC devices sending measurements in a more regular fashion. For simplicity, in this section we refer to the former group as “Non-Reliable” and to the second group as “Reliable”.

Device Type	Device Name	Available Measurements
Non-Reliable	NR1	time_send, AccumulatedEnergyUse_1, AccumulatedEnergyUse_2, AccumulatedEnergyUse_3, CurrentEnergyUse_1, CurrentEnergyUse_2, CurrentEnergyUse_3, Current_1, Current_2, Current_3, TotalAccumulatedEnergyUse, TotalCurrent, TotalCurrentEnergyUse, TotalVoltage, Voltage_1, Voltage_2, Voltage_3
	NR2	
	NR3	
	NR4	
	NR5	
	NR6	
	NR7	
Reliable	R1	time_send, <Device>_L1_ActivePower, <Device>_L1_ApparentPower, <Device>_L1_Current, <Device>_L1_ReactivePower, <Device>_L1_Voltage, <Device>_L2_ActivePower, <Device>_L2_ApparentPower, <Device>_L2_Current, <Device>_L2_ReactivePower, <Device>_L2_Voltage, <Device>_L3_ActivePower, <Device>_L3_ApparentPower, <Device>_L3_Current, <Device>_L3_ReactivePower, <Device>_L3_Voltage, <Device>_Primärstrom, <Device>_Sekundärstrom, <Device>_T0_ActivePower, <Device>_T0_ApparentPower, <Device>_T0_ReactivePower, <Device>_T1_ActiveEnergyExport, <Device>_T1_ActiveEnergyImport, <Device>_T1_ApparentEnergy, <Device>_T1_ReactiveEnergyExport, <Device>_T1_ReactiveEnergyImport, <Device>_T2_ActiveEnergyExport, <Device>_T2_ActiveEnergyImport, <Device>_T2_ApparentEnergy, <Device>_T2_ReactiveEnergyExport, <Device>_T2_ReactiveEnergyImport
	R2	
	R3	
	R4	
	R5	
	R6	

Table 1: Available devices and measurements from the CLUE DB.

Table 1 summarizes the available measurements per device type. As we can see, the devices we indicate as “Reliable” offer a much wider range of measurements. Note that the quantities labelled as “EnergyUse” actually represent power measurements. The field time_send contains the timestamp at which the data is recorded, with a nominal granularity of 1 minute. Note also that, for privacy reasons, the device names have been anonymized with the code NRx for the Non-Reliable ones, and with the code Rx for the Reliable ones.

We further summarized the main features of each available dataset in Table 2. As it is visible from the table, every device has a different number of entries, sometimes even differing of some orders of magnitudes (recall for instance that the Homee device NR4 was only used for testing purposes only). The start and end dates are also different among devices. As already mentioned in Section 5.1.20, indeed, the Homee devices proved to have poor measurement and data transmission capabilities and were replaced by the PAC2200 measuring devices - i.e., the “Reliable” devices - in a later phase of the test.

DEVICE TYPE	DEVICE NAME	START DATE	END DATE	TOTAL # ENTRIES
NON-RELIABLE	NR1	18.02.2022 13:41	26.09.2022 11:46	179120
	NR2	22.03.2022 20:02	26.09.2022 10:32	63856
	NR3	18.02.2022 13:41	26.09.2022 11:46	160888
	NR4	20.01.2022 01:02	20.01.2022 13:21	729
	NR5	20.01.2022 01:03	09.09.2022 14:43	198176
	NR6	20.01.2022 01:01	26.09.2022 11:46	201706
	NR7	20.01.2022 01:03	26.09.2022 11:46	207717
RELIABLE	R4	11.11.2022 08:47	09.03.2023 15:58	70753
	R6	19.10.2022 13:27	09.03.2023 15:59	94433
	R3	09.11.2022 14:02	09.03.2023 16:01	73233
	R5	19.10.2022 13:27	09.03.2023 16:02	94437
	R1	24.02.2022 11:02	09.03.2023 16:03	284184
	R2	24.02.2022 11:02	09.03.2023 16:05	284186

Table 2: Measurements summary per device.

5.2.4 Detection of anomalies in measurements

Three anomaly types were recognized as the most relevant for the use case: i) the detection of peaks and drops in the voltage measurements, ii) the detection of long gaps in the records, and iii) the detection of inconsistencies between the measured and the calculated power values. The following subsections describe each process in more detail.

Detection of peaks and drops in the voltage

For this task, we chose to rely on a simple threshold system: being the baseline voltage fixed at 230 V, a variation within a range of +/-7% or even up to +/-10% is considered a normal behaviour. All the records falling outside this upper and lower bound were marked as anomalous. The check was performed on all the three phases.

In the case of the Reliable devices, we took into account the quantities recorded as <Device>_Voltage_1, <Device>_Voltage_2 and <Device>_Voltage_3. None of the devices in

this category report any anomaly, confirming the good quality of the measurements and of the transmissions. As a further confirmation, we report in Table 3 the maximum and minimum value of voltage on all the three phases, for each of the Reliable devices.

DEVICE NAME	L1		L2		L3	
	Min	Max	Min	Max	Min	Max
R4	219.37	245.33	219.22	245.79	219.87	244.1
R6	228.35	243.83	228.34	243.31	227.63	242.17
R3	229.24	243.20	230.13	243.21	229.39	242.74
R5	227.48	243.32	227.82	242.85	227.08	242.59
R1	227.74	243.04	227.03	243.48	226.73	242.79
R2	227.9	242.99	227.17	243.38	226.91	242.74

Table 3: Min and Max Voltage per Reliable device.

The Homee devices showed instead more variate behaviours. While the voltage measured on the devices NR3, NR4, NR5 and NR6 proved to stay within the given range on all the three phases, devices NR1, NR2 and NR7 showed some anomalies. In most of the cases, the anomalous entries spanned all over the three phases, and covered from the 0.01% to the 3.37% of the total entries. An exception is device NR7, that showed no anomalies on phase 3, and around the 13.5% of anomalous entries on phase 1 and 2. Figure 68 reports an example of anomalous behaviour.

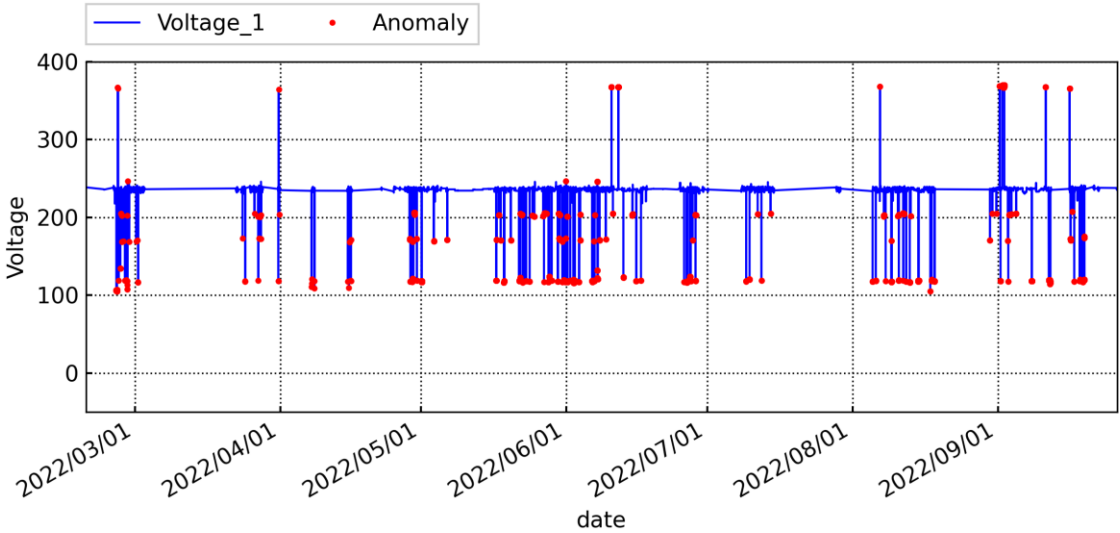

Figure 68: Voltage peaks and drops recorded on device NR1.

Detection of gaps in measurements

The second required task was the retrieval of gaps in measurements. A gap in the transmission was defined relevant if longer than 5'. For each device, a gap report was then generated including the starting time and the gap length.

DEVICE NAME	MAX GAP LENGTH	# GAPS
NR1	19 days 10:37:01	95
NR2	14 days 03:29:26	538
NR3	29 days 08:34:51	96
NR4	0 days 00:06:21	2
NR5	19 days 10:37:01	65
NR6	19 days 10:37:01	491
NR7	19 days 10:37:01	129
R4	49 days 13:24:14	26
R6	49 days 13:24:14	28
R3	49 days 13:24:14	30
R5	49 days 13:24:14	28
R1	49 days 13:24:14	147
R2	49 days 13:23:13	147

Table 4: Duration and number of recorded gaps in the dataset.

Table 4 reports the number of recorded gaps and the maximum gap length for each device. The Non-Reliable devices NR6 and NR2 register the highest number of gaps, confirming the unreliability in the measurements. The maximum gap length is recorded on the devices of type Reliable. For all the devices we record a gap of 49 days, due to deployment changes during the development phase.

Power calculation and correlation evaluation

Finally, the third task focused on evaluating the measurements' reliability by means of a power calculation and correlation analysis. The idea is to evaluate the pairwise correlation between the calculated apparent power and the available measured one. If the correlation between each of the recorded value and the calculated apparent power is above a defined threshold, we consider the measurements reliable. Two approaches have been followed, depending on the available measurements on each type of device. In both cases, each phase has been considered individually. It is also worth mentioning that, considering the presence of gaps, the correlation was not calculated on the entire signal, but on 24-hours-long moving windows.

For the Reliable devices, together with the Voltage (V) and Current (I) measurements, the active power P (W) and the reactive power Q (VAR) were available, so we proceeded calculating the apparent power S (VA) according to the following equations, repeated for each phase:

$$S = V * I \quad (1)$$

$$S^2 = P^2 + Q^2 \quad (2)$$

We used equation (1) to verify the correlation between S, V, I, and equation (2) to verify the correlation between S, P, Q. In the vast majority of the cases, the correlation value was higher than the threshold set to raise an alert, in this case 0.8. This result proved that the measurements recorded and transmitted by this category of devices are coherent with what expected.

For the Homee devices, on the other hand, the power calculation required some prior assumptions due to the unavailability of S and Q in the recorded measurements. Therefore, we assumed Q to be close to zero, to be able to apply equation (1) again. This assumption holds only for a resistive load. As a further check, we verify that the total P coincides with the sum of the active power on each phase:

$$TotalCurrentEnergyUse = CurrentEnergyUse_1 + CurrentEnergyUse_2 + CurrentEnergyUse_3 \quad (3)$$

As expected, the correlation results were significantly variable across the devices. The lowest average correlation value was registered on device NR1 (0.57 on 129 available time windows), while the highest average correlation was recorded on NR2 (0.9 on 101 available time windows).

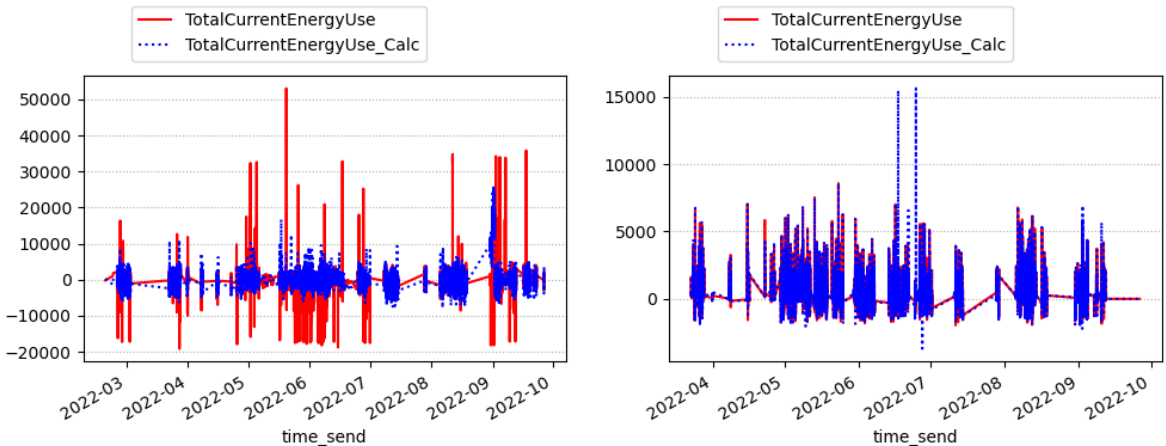

Figure 69: CurrentEnergyUse (Active Power) recorded and calculated on device NR1 (left) and NR2 (right).

Figure 69 confirms that the correlation is a good indicator for anomalous entries: device NR1 (left) presents a large number of anomalous peaks and drops in the recorded CurrentEnergyUse - mostly from CurrentEnergyUse_1 - that do not reflect the calculated values. Instead, TotalCurrentEnergyUse and TotalCurrentEnergyUse_Calc almost coincide for device NR2 (right).

6 PROOF-OF-CONCEPT COMMUNITIES/CELLS INNOVATION LAB

6.1 Establisling the REC

6.1.1 Frame Conditions

For the CLUE project a REC in Südburgenland has been established, in the demo region of the innovation lab act4.energy. With the passing of the Renewables Development Act (Erneuerbaren Ausbaugesetz, EAG) in July 2021, the legal framework for Energy Communities became established in Austria and the setup of a local, renewable energy community could be started.

Due to the regulatory framework being very new, with no prior established experiences it was decided to start with a small pilot in the municipality of Ollersdorf.

6.1.2 1st Citizen information workshop

A citizen information workshop on energy communities has been conducted on August 20th, 2021. About 40 participants were informed on energy communities in general and the presented the opportunity to participate in the research activities of the Innovation Lab act4.energy concerning REC, the CLUE project being one of them.

After the workshop 33 local households, the municipality, the primary school, kindergarden and the rectorate signed up to participate in the REC to be established.

6.1.3 Establisling the REC

Due to the regulatory framework being brand new and all related processes not being established yet, the establishing of the REC took about 5 ½ months and the energy community became fully operative (i.e. integrated in the Austrian energy market processes ebutilities via the EDA platform) in February 2022. Still, the onboarding of all pre-registered citizens was a slow process with all interested citizens onboarded by the end of 2022.

6.1.4 2nd Citizen information workshop

With the REC legally established and the citizens being onboarded a second information workshop was held on July 7th, 2022. During this workshops the Energy Account and the concept of the energy currency e-kWh were introduced to about 25 participating citizens.

The use cases of converting e-kWh into a crypto token on a Blockchain, in order to be utilized as a regional currency for E-mobility charging and paying at a local coffee shop were introduced and explained.

At this workshops the citizens also got a hands-on experience with the Energy Account and the e-kWh crypto token to be used via the Minerva Wallet of lab10 collective.

6.1.5 Test phase

After the second workshop a 3 months test phase started from July to October 2022. Within this testphase, the participants could use their Energy Account and transfer some of their generated energy currency to the Minerva wallet, creating crypto tokens in the process.

With these tokens the participants could make payments for EV – charging and in the coffee shop at the solar.one, the headquarter building of the Innovation Lab act4.energy.

6.2 The Energy Account

6.2.1 General

The energy account is a new business model, which allows to integrate all energy expenses and energy services of a customer into a single app that has been developed by the Innovation lab act4.energy as part of their living lab infrastructure.

The energy account does:

- allow the customer to easily follow all of their energy expenses (electric, heat, mobility, ...) and energy feed-in to the grid (PV, battery, bi-directional EV) in a single app. The customers energy balance between used energy and feed-in energy is kept track and displayed in an easily understandable form in a web app.
- allow energy service providers to integrate into the system and accept energy as “currency” for their services from the customers. A CSP that is partner of the system will directly charge energy (in kWh) from the customers energy account when the EV is charged.



Figure 68: Home screen of the energy account web application

The service operator of the energy account service acts as an energy service provider who does all the balancing and keeps the energy accounting data in a database system.

The Energy account keeps balance from PV production, energy consumption and energy purchases according to the following formula:

With:

- Eacc(t): account balance at time t
- C1: balance factor for feed-in power
- C2: balance factor for purchased power
- C3: balance factor for provided flexibility
- Ecorr: Energy used for external services

The energy account also can act as a customer loyalty program as users can get energy booked to their account for a variety of things, in addition to get energy accounted when their PV plant or storage battery does feed in into the grid. Energy is awarded to customers account when they take part in occasional promotions of the partners of energy account network (similar system like award miles in frequent flyer programs).

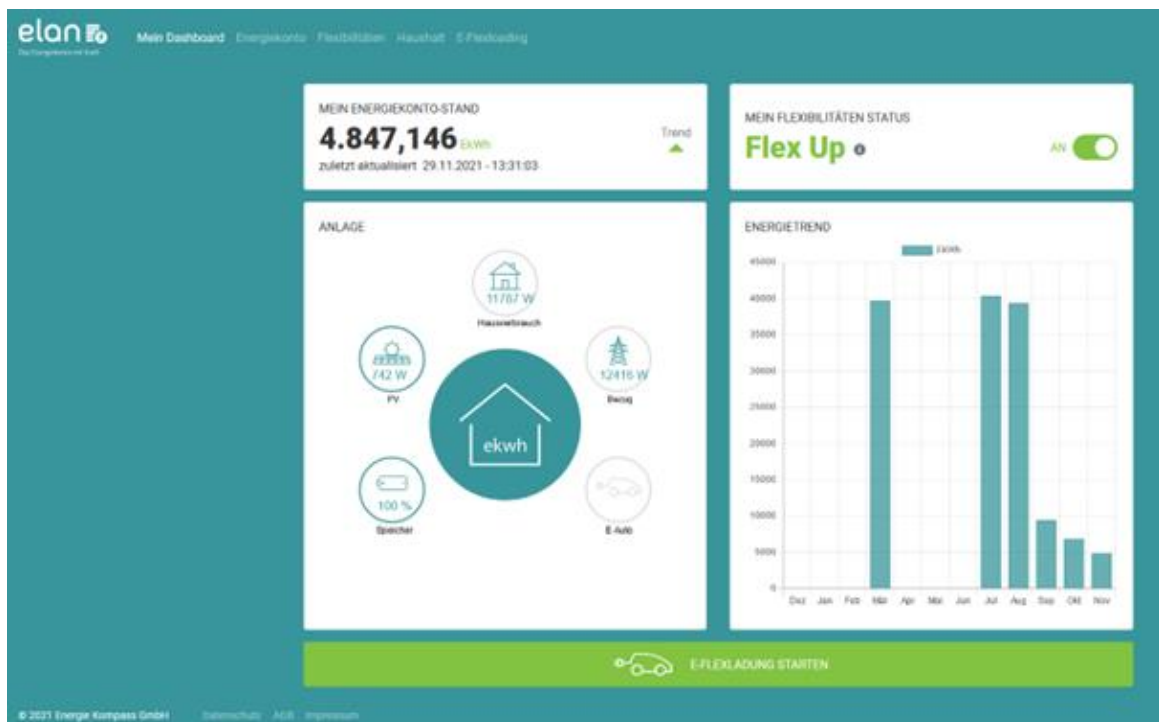

Figure 69: main dashboard of the energy account web application

6.2.2 ICT Concept

For the implementation of the energy account application, a dedicated IoT infrastructure is implemented as part of the innovation lab act4.energy, which has been utilized in the CLUE project. For this, each of the participating households is equipped with an IoT gateway device to connect between the household assets and the energy account backend.

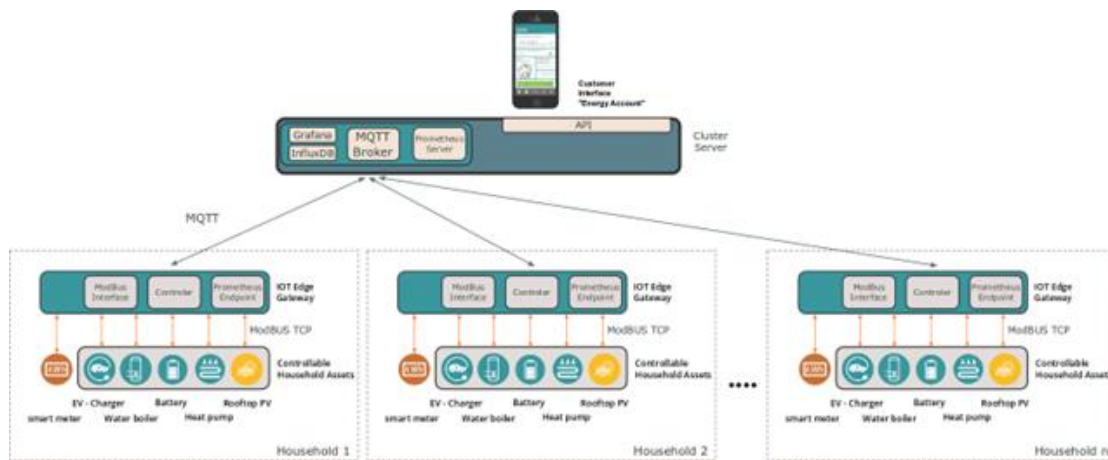

Figure 70: overview of the communication architecture for the energy account application

The IoT gateway devices connect to and communicate with household devices using MODbus TCP protocol. The communication to the central data backend is done with MQTT protocol.

For each participating household the energy account data is handled in a central database, that is operated by the innovation lab act4.energy as part of their innovation infrastructure.

6.3 Blockchain Implementation

The blockchain space is very dynamic and throughout the project we had to keep a very close connection to the main actors on several blockchain systems. The launch of the ARTIS $\Sigma 2$ blockchain network, which was planned to be used for the e-kWh Token, had to be halted by us due to the maintenance stop of the “OpenEthereum” client software. Also the simple web-wallet Minerva Cash showed that it was not sufficient to meet the usability needs for a community currency like the e-kWh Token in the project.

This demanded a thorough analysis of the available blockchain systems and their suitability for the POC implementation.

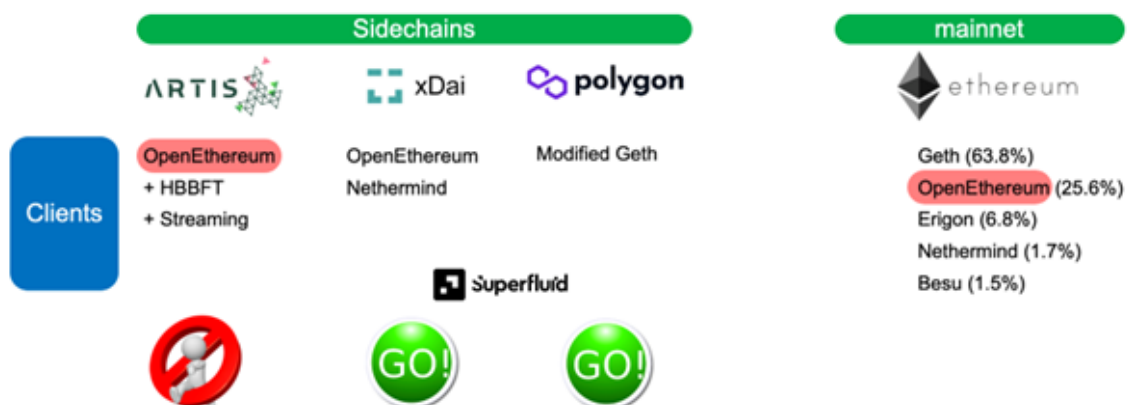

Figure 71: Analysis of programmable blockchains and their suitability for CLUE

In order to keep the option of streaming payments (demonstrated at the MIA 2019 as part of the SonnWende+ project), we have decided to use the Superfluid protocol and test the viability with the natively streamable MIVA token on the xDai Chain (now called Gnosis Chain, which

went through a major network upgrade in Dec. 2022). This experiment provided great insights on the outstanding composability of public blockchains and the complete tool chain. Decentralized Exchanges (“DEX”) for the trading of tokens and NFT’s (“Non-Fungible-Tokens”) were tested to evaluate the possible application in the CLUE project. For example there could be bonus programs with rewards or preferred access to events using various tokens.

Basically all these decentralized application (“DApp”) are equipped with a “Connect” button and they have integrated the WalletConnect protocol to connect mobile wallets. Therefore the Minerva Wallet App had to be upgraded and made available to a broader audience on the Google Play Store

6.3.1 Minerva Wallet

The Minerva Wallet is a crypto and identity wallet and as we planned to analyse the use of fully self-custodial e-kWh Token management in the demo region Ollersdorf, it was necessary to tailor the app software for the project needs.

The full compatibility with WalletConnect was needed to interact with DApps and to date Minerva is globally the only mobile wallet which supports the Superfluid protocol for streaming tokens, which has become the dominant protocol for streaming payments. Many organizations in the crypto ecosystem use it for continuous payments to their employees.



The workshop in Ollersdorf provided great insights into the usability challenges this novel technology still faces.

Some of the users did not have yet smart phones and would be excluded from the option to transfer e-kWh Tokens. Also the setup for the Kovan testnetwork was more difficult than expected and despite the plan to deploy the ekWh Token on the Gnosis Chain, it still showed that any change to a different blockchain network will cause additional challenges for the customer service.

Then there is the need to pay transaction fees with the native coin of the blockchain network. For Ollersdorf we took care about that, by providing small amounts of coins to the users, so that they didn't get confused by yet another “token”. Nevertheless, it would be best if transaction fees would be paid in the background and there would be no need to own also the

coin of the blockchain network. This is unfortunately not yet possible with the typical blockchain wallet type as the Minerva Wallet is. Only smart contract wallets, of which only very few exist, are currently capable to abstract transaction fees away, but none of them offers that option (yet).

On the other side there is a new standard on the horizon, ERC-4337 called "Account Abstraction", which might enable the payment of transaction fees by third parties. This will certainly help with the adoption and will lead to the reduction of problems connected with the transaction fee payments.

Key learnings:

- User involvement shall be as early as possible
- Technically advanced solutions are challenging when it comes to usability
- The mainstream use of blockchain tokens still needs a few more innovations to be generally applicable

6.3.2 e-kWh Token

The e-kWh Token is following the [ERC-20 token standard](#) in order to be compliant with all Ethereum compatible wallets, beside the used Minerva Wallet. Interoperability is key in the blockchain space and therefore adhering to established standards will allow composability with various open-source tools on public blockchains.

On the Energy Account system an update was needed to provide the user interface for moving e-kWh to the blockchain and 'mint' them as Tokens.

Once the e-kWh Token was minted the Energy Account database entry was updated and the Tokens could now be freely transferred on the blockchain system.

Because blockchain wallets don't need any registration, the simplicity to use such a system for payments that happen instantaneous becomes very compelling. As stated, there are still some usability challenges that need to be overcome for the mainstream, but using it as a means of payment at the act4.energy / solar.one demonstration site is already a great start.

6.3.3 API to mint "e-kWh"

In order to make the transfer of e-kWh in the Energy account to the blockchain as e-kWh Token as simple as possible, a "Token Generator" was developed, providing an API endpoint to the Energy Account system.

After providing the e-kWh Amount and the blockchain address stored in the user profile, the Token Generator mints the e-kWh Tokens on the blockchain network and if successful, it reports back that the amount of e-kWh on the Energy Account can be reduced.

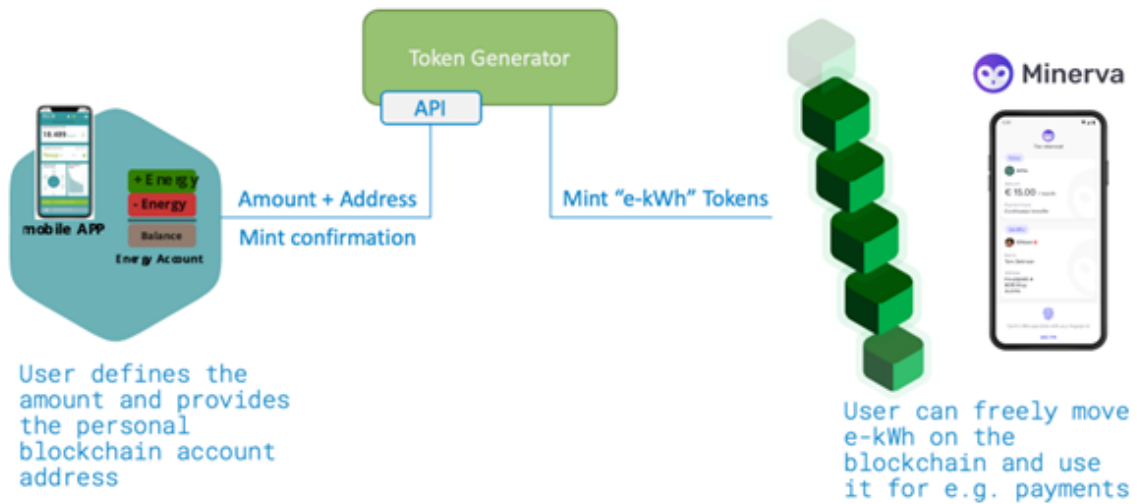

Figure 72: Schematic architecture for the Token Generator to mint e-kWh Tokens

The "Token Generator" was an essential piece of software, that allowed the background payment of transaction fees and abstraction of some of the blockchain complexities. With this, software developers don't need to know anything about blockchain technology and can get have a presentable result in just a few hours. After the second workshop a 3 months test phase started from July to October 2022.

7 LITERATURE

- Bauwens, T. & Devine-Wright, P. (2018) „Positive energies? An empirical study of community energy participation and attitudes to renewable energy“, *Energy Policy*, Vol. 118, S. 612–625.
- Bomberg, E. & McEwen, N. (2012) „Mobilizing community energy“, *Energy Policy*, Vol. 51, S. 435–444.
- Boon, F. P. & Dieperink, C. (2014) „Local civil society based renewable energy organisations in the Netherlands: Exploring the factors that stimulate their emergence and development“, *Energy Policy*, Vol. 69, S. 297–307.
- Conradie, P. D., Ruyck, O. de, Saldien, J. & Ponnet, K. (2021) „Who wants to join a renewable energy community in Flanders? Applying an extended model of Theory of Planned Behaviour to understand intent to participate“, *Energy Policy*, Vol. 151, S. 112121.
- Dóci, G., Vasileiadou, E. & Petersen, A. C. (2015) „Exploring the transition potential of renewable energy communities“, *Futures*, Vol. 66, S. 85–95.
- Hauer, D., Zeilinger, F., Mosshammer, R., Leopold T., Wilker, S. (2021) “BIFROST - A narrative simulation tool for Smart Energy scenarios - Tutorial and hands-on”, *11. Symposium Communications for Energy Systems (ComForEn)*
- Hicks, J. & Ison, N. (2018) „An exploration of the boundaries of ‘community’ in community renewable energy projects: Navigating between motivations and context“, *Energy Policy*, Vol. 113, S. 523–534
- Kalkbrenner, B. J. & Roosen, J. (2016) „Citizens’ willingness to participate in local renewable energy projects: The role of community and trust in Germany“, *Energy Research & Social Science*, Vol. 13, S. 60–70
- Martens (2022) „Investigating subnational success conditions to foster renewable energy community co-operatives - 1-s2.0-S0301421522000210-main“, *Energy Policy*, Vol. 162, 112796,
- Martilla, J. A., & James, J. C. (1977). Importance-Performance Analysis. *Journal of Marketing*, 41(1), 77–79.
- Schall, D. L. (2020) „More than money? An empirical investigation of socio-psychological drivers of financial citizen participation in the German energy transition“, *Cogent Economics & Finance*, Vol. 8, No. 1, S. 1777813
- Soeiro, S. & Dias, M. F. (2020) „Motivations for Integrating a Renewable Energy Community: Evidence for Spain and Portugal“, I

FUNDING



This document was created as part of the ERA-Net Smart Energy Systems project CLUE, funded from the European Union's Horizon 2020 research and innovation programme under grant agreement no. 775970 (RegSys).